

GROUNDING & BONDING PRODUCTS

Busbar, Insulation Products, Tools & Accessories

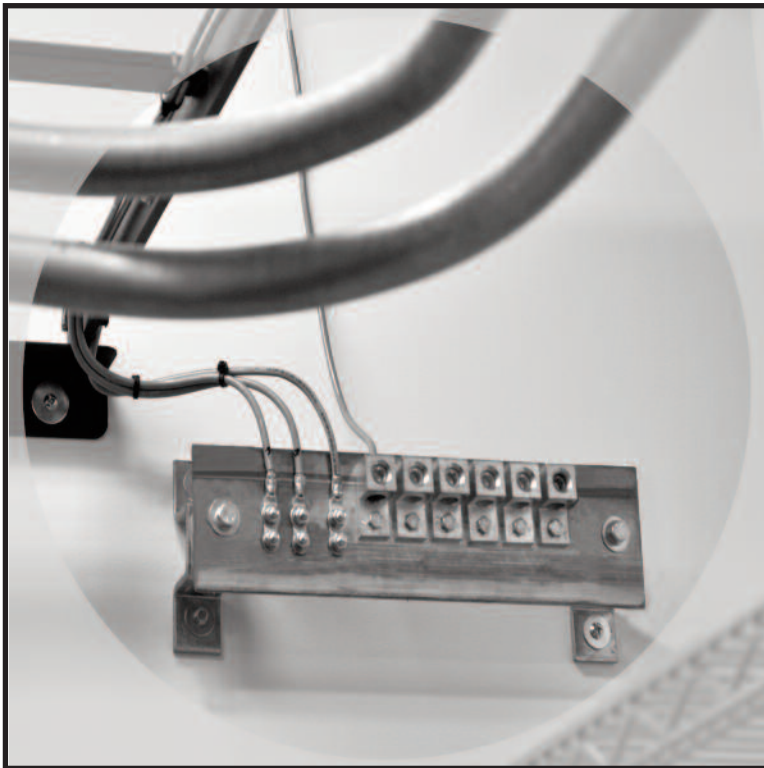

Busbars

Insulators

Grounding Products

Compression Tools, Lugs & Taps

Page 11-3

Page 11-7

Page 11-9

Page 11-14

GROUNDING & BONDING PRODUCTS

In response to the increase in newer, more sensitive, highly sophisticated electronic equipment, CPI offers a comprehensive line of UL® Listed Grounding and Bonding Products. The electrical protection and grounding of today's high-speed cabling systems is an essential part of a properly installed IT infrastructure, which is why CPI's Grounding and Bonding Products are designed to provide protection and help prevent transient voltages from damaging sensitive electronic equipment.

Stocked with a wide range of products spanning from grounding busbars and pipe clamps to ground terminal blocks and ground strap kits, CPI is equipped to handle a full list of safety codes and standards.

CPI Grounding and Bonding Products feature:

- Comprehensive line of products that promote electrical safety throughout the network
- A complete bonding solution with grounding busbars, pipe and floor pedestal clamps, insulators, joint compound, compression tools and lugs/taps, as well as other equipment
- UL Listed and compliant with industry standards



BICSI & ANSI/EIA/TIA Grounding Busbars

The CPI 13622 series Telecommunications Grounding Busbar (TGB) provides a central ground attachment point for telecommunications systems, computers and other equipment located in the data room. The CPI 40153 series Telecommunications Main Grounding Busbar (TMGB) provides a central ground attachment point for telecommunications bonding backbones, equipment and the building's ground electrode system. All CPI Grounding Busbars are UL Listed.

Hole patterns on Busbars accommodate two-hole lugs per the recommendation of BICSI NECA/BICSI 607-2011 and TIA-607-B standards. Insulators electrically isolate Busbars from the wall or other mounting surfaces, thereby controlling the current path.

- Mounting brackets are manufactured from high-quality 300 series stainless steel with 3/8" (9.53 mm) diameter mounting holes spaced 5.75" (146.1 mm) apart

- Busbars mount on the wall, floor or ceiling
- Ships preassembled
- Sold individually
- Busbar assemblies with lug kits also available
- Other configurations available on request

Each Busbar consists of:

- (1) Busbar
- (2) insulators
- (2) stand-off brackets
- (4) stainless steel bolts with Torx T-45 head
- Order installation hardware separately

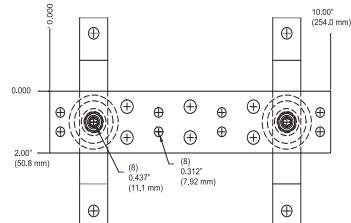

13622-010: (4) Lugs, 5/8" (15.88 mm) hole centers
(3) Lugs, 1" (25.4 mm) hole centers

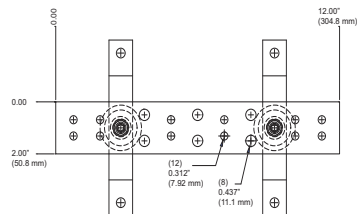

13622-012: (6) Lugs, 5/8" (15.88 mm) hole centers
(3) Lugs, 1" (25.4 mm) hole centers

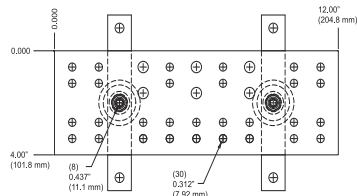

40153-012: (15) Lugs, 5/8" (15.88 mm) hole centers
(3) Lugs, 1" (25.4 mm) hole centers

Part Number	Description in (mm)	Busbar Size H x W x D in (mm)	Shipping Weight lb (kg)
13622-010	10 (250) TGB	2 x 10 x 1/4 (50 x 250 x 6.4)	3 (1.4)
13622-012	12 (300) TGB	2 x 12 x 1/4 (50 x 300 x 6.4)	4 (1.8)
40153-012	12 (300) TMGB	4 x 12 x 1/4 (50 x 100 x 6.4)	7 (3.2)
40153-020	20 (510) TMGB	4 x 20 x 1/4 (50 x 510 x 6.4)	8 (3.6)

Note: See details at left for lug sizes and quantities. Overall height with stand-off brackets is 6.63" (168 mm); overall depth is 3.13" (80 mm).

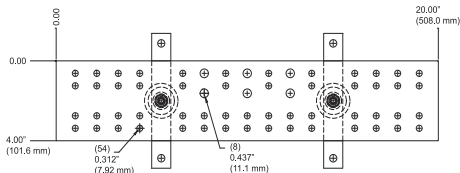

40153-020: (27) Lugs, 5/8" (15.88 mm) hole centers
(3) Lugs, 1" (25.4 mm) hole centers



Standard Busbars

CPI Standard Busbars are insulated ground bus mounting plates specifically designed for commercial applications. The hard-drawn electrolytic tough pitch 110 alloy solid copper ground bars are 1/4" (6.4 mm) thick and stand off 2.75" (69.9 mm) from the backboard or wall. The 10" (250 mm) Busbar accepts 1/4" single bolt lugs. The 12" and 20" (300 mm and 510 mm) Busbars provide connection for nine or 17 lugs respectively, accepting lugs with either 3/4", 1" or 1-3/4" (19.1 mm, 25 mm or 44.5 mm) center. Any lug with 3/8" bolts may be used.

- All Busbars ship individually and preassembled
- Other configurations available on request
- UL Listed

Each Busbar assembly consists of:

- (1) Busbar
- (2) insulators
- (2) stand-off brackets
- (4) stainless steel bolts with Torx T-45 head
- Order installation hardware separately

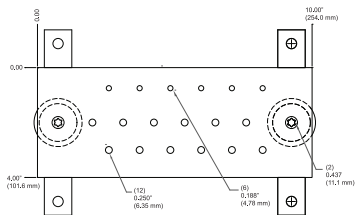

10622-010

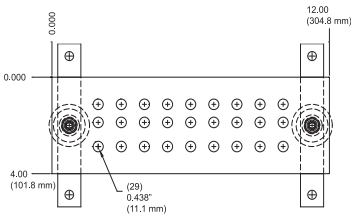

10622-012

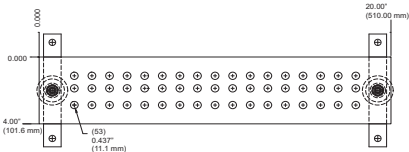

10622-020

Part Number	Description	Size H x W x D in (mm)	Shipping Weight lb (kg)
10622-010	Busbar	4 x 10 x 1/4 (100 x 250 x 6.4)	4 (1.8)
10622-012	Busbar	4 x 12 x 1/4 (100 x 300 x 6.4)	5 (2.3)
10622-020	Busbar	4 x 20 x 1/4 (100 x 510 x 6.4)	8 (3.6)

Overall height with stand-off brackets is 6.63" (168 mm); overall depth is 3.13" (80 mm).

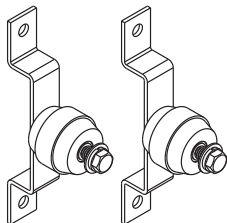

Sold in pairs

Busbar Insulator Assemblies

CPI also offers standalone Busbar Insulator Assemblies.

- Ships preassembled
- Replaces CPI P/N 13622-000

Pair of assemblies consists of:

- (2) stainless steel bolts, 3/8"W x 5/8"L
- (4) lock washers, 3/8"
- (4) flat washers, 3/8"
- (2) stainless steel bolts, 3/8"W x 3/4"L
- (2) insulators, 1-3/4"W x 1-7/8"D, 3/8" threaded insert
- (2) stainless steel wall brackets, 1"W (25 mm), 1" standoff
- Order installation hardware separately

Part Number	Description	Shipping Weight lb (kg)
10622-000	Busbar Insulator Assemblies, 1 Pair	2 (0.9)

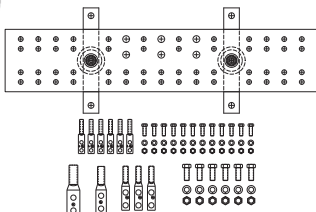

40158-020 Shown

Busbar Assemblies With Lug Kits

Busbar Assemblies with Lug Kits contain the CPI 13622 series Telecommunications Grounding Busbar (TGB) or the CPI 40153 series Telecommunications Main Grounding Busbar (TMGB) along with required stainless steel hardware to fasten the two-hole ground lugs to the Busbar.

- #6 lugs are 2-hole lugs with 1/4" hardware
- #2, 2/0 and 4/0 lugs are 2-hole lugs with 3/8" hardware
- Order installation hardware separately
- UL Listed

Part Number	Description	Busbar Size H x W x D in (mm)	#2 Lug	#6 Lug	2/0 Lug	4/0 Lug	Shipping Weight lb (kg)
40156-012	TGB Pattern	2 x 12 x 1/4 (50 x 300 x 6.4)	3 ea	6 ea	1 ea	0	5 (2.3)
40158-012	TMGB Pattern	4 x 12 x 1/4 (100 x 300 x 6.4)	3 ea	6 ea	1 ea	1 ea	8 (3.6)
40158-020	TMGB Pattern	4 x 20 x 1/4 (100 x 510 x 6.4)	3 ea	6 ea	1 ea	1 ea	11 (5.0)

Overall height with stand-off brackets is 6.63" (168 mm); overall depth is 3.13" (80 mm).

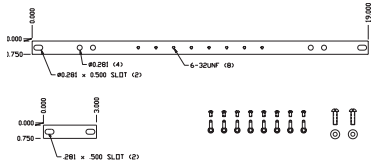

19" rack width Busbar shown

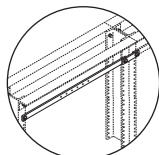

Shown mounted to rack

Horizontal Rack Busbar

Horizontal Rack Busbar for consolidating equipment grounds. Constructed of 3/16"-thick x 3/4"H (4.763 mm x 19.1 mm) hard-drawn electrolytic tough pitch 110 alloy copper bar with eight #6-32 tapped lug mounting holes on 1" (25.4 mm) centers and two pairs of 5/16" (7.938 mm) diameter holes spaced 3/4" (19.1 mm) apart for attaching ground jumpers.

- Other configurations available on request
- UL Listed

Part number consists of Busbar and a hardware kit that includes:

- (1) splice plate bar, 3"L (80 mm)
- (2) #12-24 copper machine screws
- (2) #12 copper flat washers
- (8) #6-32 copper machine screws
- (8) #6 ring terminals
- Order installation hardware separately

Part Number	Description	Rack Width (in)	Shipping Weight lb (kg)
10610-019	Horizontal Rack Busbar	19	2 (0.9)
10610-023	Horizontal Rack Busbar	23	3 (1.4)
10610-035	Horizontal Rack Busbar	35	4 (1.8)

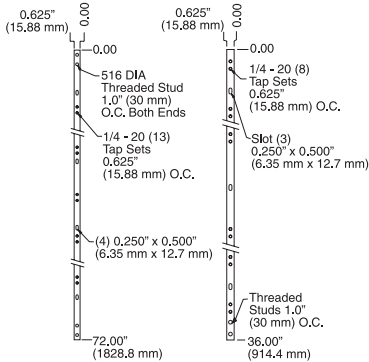

Vertical Rack Busbar

Vertical Rack Busbar for consolidating equipment grounds. Constructed of 5/8" H x 1/4" W (15.88 mm x 6.4 mm) hard-drawn electrolytic tough pitch 110 alloy copper bar with pairs of #1/4-20 tapped mounting holes on 5/8" (15.88 mm) centers. The 36" L (910 mm) bar has one set of #5/16 self-clinching studs on 1" (25.4 mm) centers at one end for attachment of a ground conductor. The 72" L (1830 mm) bar has two sets of #5/16 self-clinching studs on 1" (25.4 mm) centers at both ends for attachment of a ground conductor.

- Each package contains one Vertical Rack Busbar
- Vertical Rack Busbars with insulators and lug kits are also available
- Other configurations are available on request
- UL Listed

Part Number	Description H x W x D in (mm)	Number of Lugs	Shipping Weight lb (kg)
40160-036	5/8 x 1/4 x 36 (15.88 x 6.4 x 910)	8	4 (1.8)
40160-072	5/8 x 1/4 x 72 (15.88 x 6.4 x 1830)	13	5 (2.3)

Vertical Rack Ground Bar Kit

The Rack Ground Bar Kit includes a thin strip of tinned copper that attaches to the rack's equipment mounting rail to provide direct ground contact for rack-mount equipment or a convenient bonding strip. Sized to fit a 7" (2.1 m) high rack with an EIA-310-D Universal hole pattern and 45U, the ground bar is punched with a series of holes that align with each mounting hole on the rack. When equipment is mounted to the rack, the rack-mount brackets touch the ground bar. Alternately, the Equipment Ground Jumper Kit can be used to connect equipment to the grounding bar.

- Each kit includes one ground bar, three #12-24 zinc-plated thread forming hex washer head installation screws, an abrasive pad, joint compound and a ground label
- The ground bar is .05" (1.3 mm) thick tinned copper strip, 78.65" H x .68" W (1997 mm x 17 mm) and is punched with holes that match the EIA-310-D Universal Hole Pattern
- UL Listed Ground Bar

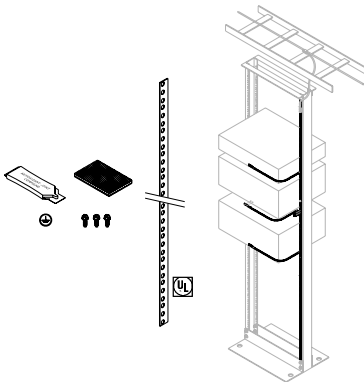

Part Number	Description	Shipping Weight lb (kg)
40172-001	Rack Ground Bar Kit	2 (0.9)

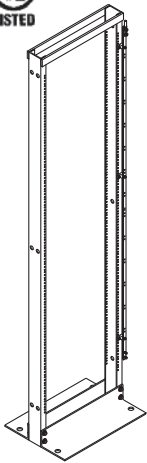

Shown mounted to rack



Vertical Rack Busbar Kits

Vertical Rack Busbar Kits isolate the Busbar from the rack to help control current paths from passing through one piece of equipment to another.

- Other configurations are available on request
- UL Listed

Kit consists of:

- (1) Vertical Rack Busbar
- (1) #2 AWG two-hole ground compression lug with 3/8" (9.53 mm) holes on 1" (25.4 mm) centers
- (3) white Delrin® insulator blocks
- (3) self-tapping screws
- (3) #12-24 mounting screws
- (2) stainless steel lock washers, 5/16"
- (2) nuts

Part Number	Description H x W x D in (mm)	Shipping Weight lb (kg)
40161-036	5/8 x 1/4 x 36 (15.88 x 6.4 x 910)	6 (2.7)
40161-072	5/8 x 1/4 x 72 (15.88 x 6.4 x 1830)	7 (3.2)

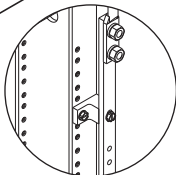
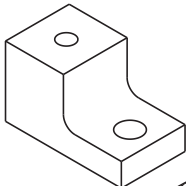

Shown mounted between rack and Busbar

Rack Busbar Insulator Block

Rack Busbar Insulator Blocks provide rigid support to physically separate Rack Busbars from all sources of electrical energy. Its offset design securely attaches the Busbar using a #12 self-tapping screw while allowing unobstructed access to rack-mounted equipment. The Insulator Block has a #12 clearance hole for mounting to the rack.

- Made of durable, nonconductive white Delrin®
- Block measures 3/4"H x 11/16"W x 1-1/4"L (19.1 mm x 17.463 mm x 31.8 mm)
- Available individually or in packages of 50

Part Number	Description	Shipping Weight lb (kg)
40157-001	Insulator Block, Each	1 (0.5)
40157-050	Insulator Block, Box of 50	2 (0.9)

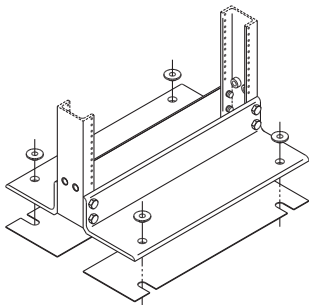

Rack Base Insulator Kit

Rack Base Insulator Kits electrically isolate the racks from the floor for an effective grounding and bonding system. Made of .060" (1.52 mm) thick phenolic insulating material and accepts up to 1/2" diameter screws. Used on concrete floors, not needed for access floor applications.

Kit consists of:

- (2) isolation plates
- (4) isolation grommets

Part Number	Description	Shipping Weight lb (kg)
10605-019	Insulator Kit, 19" Rack	3 (1.4)
10605-023	Insulator Kit, 23" Rack	3 (1.4)



Cable Runway Insulator Bar Kit

Electrically isolates Cable Runway sections, isolating grounded sections of runway or where strong EMI/RFI fields could generate eddy-currents, which could disturb down-line equipment.

- Made of durable, nonconductive white Delrin®
- Available individually or in packages of 10

Kit consists of:

- (2) insulator bars, 1.5"H x 3/8"W x 5.5"L (38 mm x 9.53 mm x 140 mm)
- (2) butt-splice kits (P/N/ 11301-001)

Part Number	Description	Shipping Weight lb (kg)
10842-001	Insulator Bar Kit, 1 Kit	3 (1.4)
10842-010	Insulator Bar Kit, 10 Kits	25 (11.3)

Cable Runway Ground Strap Kit

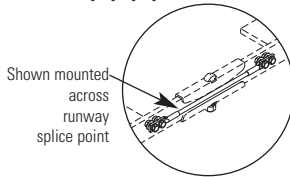
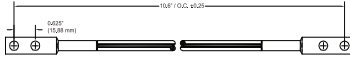

Cable Runway Ground Strap Kits provide a ground pathway between cable runway lengths when fastened together across splices. Installation requires drilling 5/16" holes. Ground Straps consist of an 8" L (200 mm) #6 AWG green insulated stranded copper conductor with horizontal yellow stripe attached at both ends to two-hole compression lugs with 1/4" bolt holes spaced on 5/8" (15.88 mm) centers.

- Overall length of 11" (280 mm)
- Available individually or in packages of 25
- Constructed of UL Listed components
- Replaces CPI P/N 12061-001
- Other configurations available on request

Kit consists of:

- (4) stainless steel cap screws, #1/4-20 x 3/4"L
- (4) flat washers, 1/4"
- (4) lock washers, 1/4"
- (4) nuts, 1/4"

Part Number	Description	Unit	Shipping Weight lb (kg)
40164-001	#6 AWG Ground Strap	1	1 (0.5)
40164-025	#6 AWG Ground Strap	25	12 (5.0)

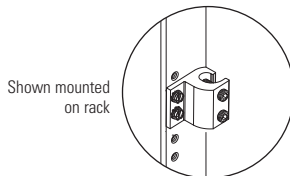
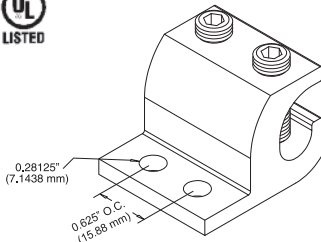

Two Mounting Hole Ground Terminal Block

CPI's Two Mounting Hole Ground Terminal Block provides a convenient way to attach ground wires to racks or cabinets and meets BICSI and ANSI-J-STD-607-A two-hole mounting recommendations. Constructed of extruded, high-strength aluminum and accepts conductors ranging from #14 AWG through 2/0. Includes two #3/8-24 x 7/8"L stainless steel set screws.

- Manufactured from electroplated tin aluminum
- UL Listed
- Available individually or in packages of 10
- Mounting hardware not included

Part Number	Description	Unit	Wire Size	Shipping Weight lb (kg)
40167-001	Two-Hole Block	1	#14-2/0	1 (0.5)
40167-010	Two-Hole Block	10	#14-2/0	10 (4.5)

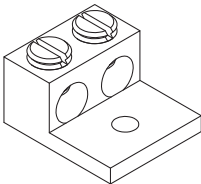

Zinc Plated

One Mounting Hole Ground Terminal Block

CPI's traditional One Mounting Hole Ground Terminal Block provides a convenient way to attach ground wires to racks or cabinets using one #12-24 screw (not supplied). Holds up to two #4 gauge wires.

Part Number	Description	Unit	Wire Size	Shipping Weight lb (kg)
08009-001	One-Hole Block	1	Up to #4	1 (0.5)
08009-010	One-Hole Block	10	Up to #4	10 (4.5)

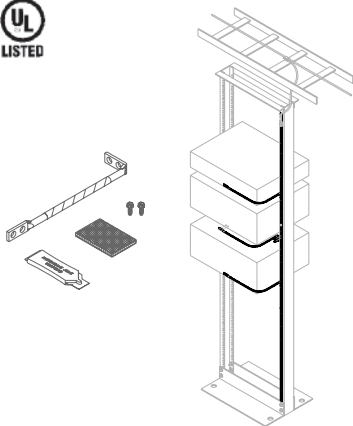

Equipment Ground Jumper Kit

Use the Equipment Ground Jumper Kit with the Vertical Rack Busbar Kit or Rack Ground Bar Kit to bond rack-mount equipment. The Equipment Ground Jumper Kit includes a 24"L (710 mm) insulated green/yellow helical stripe #6 AWG ground conductor with a Slotted Compression Lug on one end and a 90° Slotted Compression Lug on the other end. The 90° Slotted Lug attaches to the busbar or ground bar allowing easy alignment with equipment. The Slotted Compression Lug attaches to equipment. The kit includes an abrasive pad, antioxidant joint compound and two installation screws to prepare and secure the jumper to the busbar or ground bar. The installer must provide installation hardware for the lug that attaches to equipment.

- Each kit includes one 24"L (710 mm) insulated ground jumper with attached lugs, two plated installation screws, an abrasive pad and joint compound
- The lugs are made from electroplated tinned copper and have two mounting holes spaced .5" to .625" apart that accept 1/4" screws
- UL Listed Components

Part Number	Description	Shipping Weight lb (kg)
40159-010	Equipment Ground Jumper Kit	2 (0.9)



Ground Wire

Use Ground Wire to create custom-length ground jumpers to bond CPI Racks, Cabinets and Cable Runway to Telecommunications Grounding Busbars.

- Ground Wire is a #6 AWG, 133-strand, green insulated MTW conductor with a yellow helical stripe
- Sold in a 100' (30 m) length on a spool
- High strand count requires specific Compression Lugs (40162-913, 40162-963, 4012-914 or 40162-964)

Part Number	Description Length ft (m)	Shipping Weight lb (kg)
40159-001	Ground Wire, #6 AWG, 100 (30) Spool	14 (6.4)



Ground Jumper



Shown mounted on rack

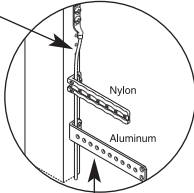

Ground Jumpers provide common grounding from equipment rack or cabinet to the Telecommunications Equipment Bonding Conductor. Can be used with CPI "L" Brackets (P/N 10001-001 or 10559-500) to attach cable run vertically along equipment rack or cabinet. Ground jumpers are constructed of a 9'L (2.7 m) #6 AWG stranded copper conductor insulated green with a horizontal yellow stripe attached to a compression lug with two 1/4" bolt holes spaced on 5/8" centers.

- Available individually or in packages of 10
- Constructed of UL Listed components
- Replaces CPI P/N 41016-00X and 41026-00X
- Other configurations available on request

Part Number	Description Length ft (m)	Unit	Shipping Weight lb (kg)
40159-009	9 (2.7) Green Jumper	1	2 (0.9)
40159-019	9 (2.7) Green Jumper	10	20 (9.1)

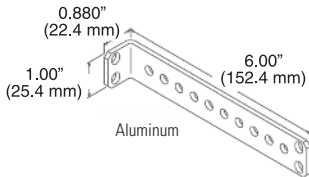
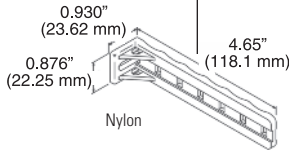

Stand-Off Tie-Down "L" Brackets

These "L" brackets mount to the back of the rack channel to provide a convenient tie-down point for grounding and bonding cable runs. Available in nonconductive nylon or high-strength aluminum construction. Either end of the aluminum bracket can be attached to the rack or cabinet face, allowing cable run in several different ways.

Part Number	Description W x L in (mm)	Unit	Shipping Weight lb (kg)
10001-001	1 x 5 (30 x 130) White Nylon	1	1 (0.5)
10001-050	1 x 5 (30 x 130) White Nylon	50	3 (1.4)
10559-X00	1 x 6 (30 x 150) Aluminum	1	1 (0.5)
10559-X50	1 x 6 (30 x 150) Aluminum	50	5 (1.4)

X=color: 1=Gray, 2=White, 5=Clear, 7=Black

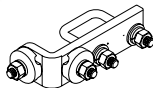

Cross Connector

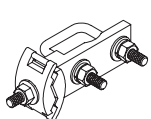
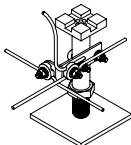

Straight Connector

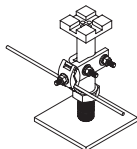

Pedestal Clamp with Ground Connector

Support ground wires from round or square raised floor pedestals using the Pedestal Clamp with Grounding Connector. The connector provides a ground connection for the pedestal and supports up to four wires from the pedestal. Use to create a signal reference grid under the raised access floor using #6 AWG or 2/0 bare round wire. Select the Pedestal Clamp with Grounding Connector to match the style and size of the pedestal and size of the conductor.

- Use Cross Connectors to create signal reference grid intersections; support up to four conductors, two per side, size #6 AWG or 2/0
- Use Straight Connectors to support the signal reference grid in between intersections; support one or two conductors on one side of the pedestal only, size #6 AWG or 2/0
- Manufactured from electrotin plated copper or bronze (P/N 40169-003) with stainless steel installation hardware
- Part numbers 40169-001 and 40169-002 are UL Listed

Part Number	Description	Pedestal Style, Diameter in (mm)	Number and Size of Connectors	Shipping Weight lb (kg)
40169-001	Pedestal Clamp, Cross Connector	Square, 1-1/8 (28) OD	(2) #6 AWG per side	2 (0.9)
40169-002	Pedestal Clamp, Cross Connector	Round, 1-1/8 (28) to 1-3/4 (44) OD	(1) #6 AWG and (1) 2/0 per side	2 (0.9)
40169-003	Pedestal Clamp, Straight Connector	Square or Round, 1-1/8 (28) OD	(2) #6 AWG or (2) 2/0 one side only	2 (0.9)

Note: P/N 40169-003 can support two conductors that are the same size; conductors can be #6 AWG through 2/0.

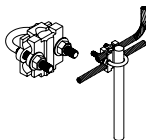

Pipe Clamp with Ground Connector

Support ground wires from metal pipes of various sizes with the Pipe Clamp with Grounding Connector. The connector provides a ground connection for the pipe and supports up to two wires parallel or perpendicular to the pipe. Select the Pipe Clamp with Grounding Connector to match the size of the pipe.

- Attaches to pipes ranging in size from .5" to 6" nominal (.375" to 6.63" outside diameters)
- Supports one or two conductors; conductors must be the same size
- Use with conductors ranging in size from #6 up to 250 MCM
- Attach conductors parallel or perpendicular to the pipe
- Manufactured from electroplated tinned bronze with stainless steel hardware

Part Number	Description	Pipe Size / Diameter Ranges Nominal Size / Outside Diameter in (mm)	Shipping Weight lb (kg)
40170-001	Pipe Clamp	5-7.5 (10-19) .375-1 (9.5-30)	2 (0.9)
40170-002	Pipe Clamp	1-1.25 (30-31.8) .75-1.7 (19-43)	2 (0.9)
40170-003	Pipe Clamp	1.5-2 (38-50) 1-2.4 (30-61)	2 (0.9)
40170-004	Pipe Clamp	2.5-3 (64-80) 2.25-3.5 (58-89)	2 (0.9)
40170-005	Pipe Clamp	3.5-4 (89-100) 3.2-4.5 (81-114)	2 (0.9)
40170-006	Pipe Clamp	5-6 (130-150) 5.63-6.63 (143-169)	2 (0.9)

Note: P/N 40170-001 supports parallel attachment of only one conductor or perpendicular attachment of two conductors. All other clamps support parallel or perpendicular attachment of two conductors. Conductors must be the same size.

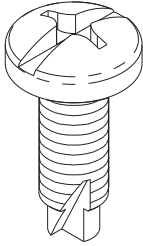

Clean-Thread Screws

The #12-24 Combination Pan Head, Pilot Point Mounting Screws attach equipment to racks and cabinets. A cutting notch in the thread removes paint in threaded holes to improve metal-to-metal contact. The pilot point reduces cross-threading. The combination head can be used with #3 Phillips and slotted screwdrivers.

- Zinc finish
- Available in packages of 50 and 1,000

Part Number	Description	Unit	Shipping Weight lb (kg)
40605-001	#12-24 Screws	50	1 (0.5)
40605-004	#12-24 Screws	1,000	9 (4.1)

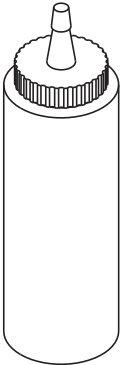

8 oz (230 g)

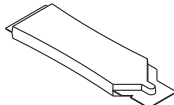

.5 oz (14 g)

Aluminum-To-Aluminum Or Aluminum-To-Copper Antioxidant Joint Compound

Recommended for all aluminum-to-aluminum and aluminum-to-copper connectors, bare conductors, Busbars, insulated conductors and conduit threads.

Part Number	Description	Size oz (g)	Unit	Shipping Weight lb (kg)
40166-101	Antioxidant, Gray	.5 (14)	1	1 (0.5)
40166-801	Antioxidant, Gray	8 (230)	1	1 (0.5)
40166-150	Antioxidant, Gray	.5 (14)	50	2 (0.9)
40166-812	Antioxidant, Gray	8 (230)	12	6 (2.7)

- Oxide inhibiting joint compound is used to improve the electrical conductivity and enhance the integrity of any grounding or bonding connection
- Good for all voltages
- Assures a high-connectivity joint by sealing out air and moisture to prevent corrosion and reformation of oxide film
- Also used as an anti-seizing thread lubricant and ensures continuity of ground on aluminum conduit threads
- Bulk packaging quantities available

Copper-To-Copper Joint Compound

Recommended for all copper-to-copper connections, copper threads and all mechanical/pressure type grounding connections.

Part Number	Description	Size	Unit	Shipping Weight lb (kg)
40168-101	Antioxidant, Copper	.5 oz	1	1 (0.5)
40168-801	Antioxidant, Copper	8 oz	1	1 (0.5)
40168-150	Antioxidant, Copper	.5 oz	50	2 (0.9)
40168-812	Antioxidant, Copper	8 oz	12	6 (2.7)



Compression Tool



Crimp Tool



Mechanical Compression Tools

Mechanical Compression Tools are used to attach compression lugs and butt splices (not recommended for use with C-Tap connections). The tools feature long steel handles with comfortable rubber grips. The Dieless Compression Tool works with either copper or aluminum conductors. The Crimp Tool comes complete with dies and features extra-long handles for two-handed crimping.

Part Number	Description	Conductor Size	Length in (mm)	Shipping Weight lb (kg)
40165-001	Compression Tool, Dieless	Copper #8-250 MCS Aluminum #8-4/0	24 (610)	5 (2.3)
40165-002	Crimp Tool	#8-1/0	10.5 (267)	3 (1.4)

Compression Lugs

Connect copper or tinned copper conductors to Busbars, racks, cabinets or Cable Runway.

- Manufactured from electroplated tinned copper conductors
- Available individually or in bulk quantities in three styles; Two-Hole, Slotted and 90° Slotted
- Other configurations available

Part Number	Description	Cable Size	Hole Spacing in (mm)	Hole Size in (mm)	Color Code	Quantity	Shipping Weight lb (kg)
40162-901	Two-Hole Lug	#6	.625 (15.9)	.250 (6.4)	Blue	1	1 (0.5)
40162-951	Two-Hole Lug	#6	.625 (15.9)	.250 (6.4)	Blue	50	2 (0.9)
40162-902	Two-Hole Lug	#6	.750 (19.1)	.375 (9.5)	Blue	1	1 (0.5)
40162-952	Two-Hole Lug	#6	.750 (19.1)	.375 (9.5)	Blue	50	2 (0.9)
40162-903	Two-Hole Lug	#6	1.00 (25.4)	.375 (9.5)	Blue	1	1 (0.5)
40162-953	Two-Hole Lug	#6	1.00 (25.4)	.375 (9.5)	Blue	50	2 (0.9)
40162-904	Two-Hole Lug	#2	.625 (15.9)	.250 (6.4)	Brown	1	1 (0.5)
40162-954	Two-Hole Lug	#2	.625 (15.9)	.250 (6.4)	Brown	25	2 (0.9)
40162-905	Two-Hole Lug	#2	.750 (19.1)	.375 (9.5)	Brown	1	1 (0.5)
40162-955	Two-Hole Lug	#2	.750 (19.1)	.375 (9.5)	Brown	25	2 (0.9)
40162-907	Two-Hole Lug	#2	1.00 (25.4)	.375 (9.5)	Brown	1	1 (0.5)
40162-957	Two-Hole Lug	#2	1.00 (25.4)	.375 (9.5)	Brown	25	2 (0.9)
40162-909	Two-Hole Lug	2/0	1.00 (25.4)	.375 (9.5)	Black	1	1 (0.5)
40162-959	Two-Hole Lug	2/0	1.00 (25.4)	.375 (9.5)	Black	10	2 (0.9)
40162-910	Two-Hole Lug	2/0	1.75 (44.5)	.500 (12.7)	Black	1	2 (0.9)
40162-960	Two-Hole Lug	2/0	1.75 (44.5)	.500 (12.7)	Black	10	2 (0.9)
40162-911	Two-Hole Lug	4/0	1.00 (25.4)	.375 (9.5)	Purple	1	1 (0.5)
40162-961	Two-Hole Lug	4/0	1.00 (25.4)	.375 (9.5)	Purple	10	2 (0.9)
40162-912	Two-Hole Lug	4/0	1.75 (44.5)	.500 (12.7)	Purple	1	1 (0.5)
40162-962	Two-Hole Lug	4/0	1.75 (44.5)	.500 (12.7)	Purple	10	3 (1.4)
40162-913	Slotted Lug	#6	.500 (12.7)/.625 (15.9)	.250 (6.4)	Blue	1	1 (0.5)
40162-963	Slotted Lug	#6	.500 (12.7)/.625 (15.9)	.250 (6.4)	Blue	25	2 (0.9)
40162-914	90° Slotted Lug	#6	.500 (12.7)/.625 (15.9)	.250 (6.4)	Blue	1	1 (0.5)
40162-964	90° Slotted Lug	#6	.500 (12.7)/.625 (15.9)	.250 (6.4)	Blue	25	2 (0.9)

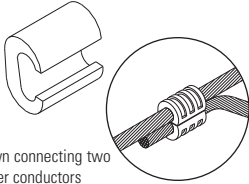

Shown connecting two copper conductors

C-Type Compression Taps

C-Type Compression Taps connect two copper conductors with the use of a hydraulic crimping tool.

- Available individually or in bulk packages
- Other sizes available on request
- UL Listed

Part Number	Description	Run	Tap	Unit	Shipping Weight lb (kg)
40163-004	C Taps	#2 Stranded #2 Solid	#2 Stranded #2 Solid	1	1 (0.5)
40163-054	C Taps	#2 Stranded #2 Solid	#2 Stranded #2 Solid	50	4 (1.8)
40163-003	C Taps	#2 Stranded #2 Solid	#4 Stranded #8 Solid	1	1 (0.5)
40163-053	C Taps	#2 Stranded #2 Solid	#4 Stranded #8 Solid	50	6 (2.7)
40163-002	C Taps	#4 Stranded #4 Solid	#4 Stranded #6 Solid	1	1 (0.5)
40163-052	C Taps	#4 Stranded #4 Solid	#4 Stranded #6 Solid	50	3 (1.4)
40163-001	C Taps	#4 Stranded #6 Solid	#6 Stranded #6 Solid	1	1 (0.5)
40163-051	C Taps	#4 Stranded #6 Solid	#6 Stranded #6 Solid	50	3 (1.4)
40163-005	C Taps	2/0 Stranded 1/0 Solid	#2 Stranded #8 Solid	1	1 (0.5)
40163-055	C Taps	2/0 Stranded 1/0 Solid	#2 Stranded #8 Solid	10	1 (0.5)
40163-007	C Taps	2/0 Stranded 1/0 Solid	2/0 Stranded 1/0 Solid	1	1 (0.5)
40163-057	C Taps	2/0 Stranded 1/0 Solid	2/0 Stranded 1/0 Solid	10	1 (0.5)
40163-006	C Taps	4/0 Stranded 3/0 Solid	#2 Stranded #6 Solid	1	1 (0.5)
40163-056	C Taps	4/0 Stranded 3/0 Solid	#2 Stranded #6 Solid	10	1 (0.5)
40163-008	C Taps	4/0 Stranded 3/0 Solid	2/0 Stranded 1/0 Solid	1	1 (0.5)
40163-058	C Taps	4/0 Stranded 3/0 Solid	2/0 Stranded 1/0 Solid	10	2 (0.9)
40163-009	C Taps	4/0 Stranded 3/0 Solid	4/0 Stranded 3/0 Solid	1	1 (0.5)
40163-059	C Taps	4/0 Stranded 3/0 Solid	4/0 Stranded 3/0 Solid	10	2 (0.9)