

# Product Information Sheet

## JACK PLATE WALL MOUNTING BRACKET

This innovative flush-mount wall board bracket is designed to hold round style modular jack plate assemblies. To install, simply drill a 2 3/8" diameter hole into dry wall, insert bracket into hole and, using a flat blade screwdriver, tighten patented sure-grip pads to hold securely in place. Adjustable pads handle most wall sizes up to 1" thick.

Clear plastic flush mount design is invisible when installed. Four screws hold pattern to fit round modular jack rings. Includes two #6-32 machine screws. For AT&T and Regional Bell Operating Co. use with modular jack plate assemblies such as Allen-Tel AT218 or Suttle SE-625B2 (not included).

Part Number	Description	Shipping Weight
20502-002	Jack Plate Wall Mounting Bracket	1 lb
20502-022	Jack Plate Wall Mounting Bracket in carton of 200	12 lb

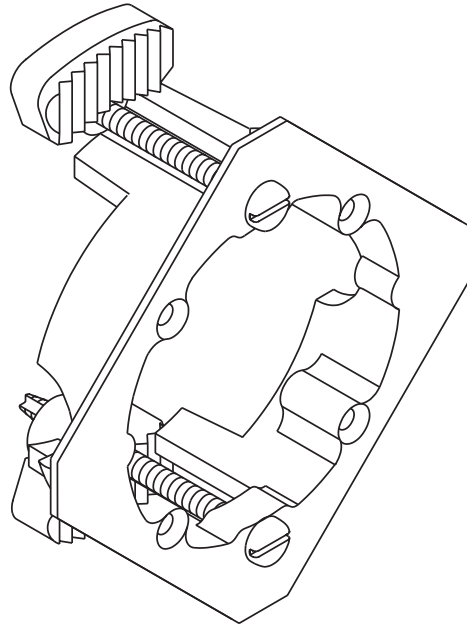

800-834-4969 in US & Canada • [www.chatsworth.com](http://www.chatsworth.com)



CHATSWORTH PRODUCTS, INC.

©2002 Chatsworth Products, Inc. 5/02/GT