

# N-SERIES TERAFRAME® NETWORK CABINET FOR THE CISCO® NEXUS 7018 SWITCH

## KEY FEATURES

- Designed specifically to deploy a Cisco Nexus 7000 Series 18-slot switch (Nexus 7018) in a hot aisle/cold aisle data center environment
- An integrated Network Switch Exhaust Duct converts side-to-side airflow through the switch into front-to-rear airflow through the cabinet, allowing the cabinet to be deployed in hot aisle/cold aisle applications
- Offset, removable doors and side panels provide extra interior space around equipment for enhanced side-to-side airflow and easy access to equipment and cabling
- Large brush-sealed openings on the top of the cabinet allow large quantities of cables to enter or exit the cabinet
- Includes T-shaped cable guides on the front of the cabinet with openings that align with each rack-mount unit to divide and organize cables as they enter or exit the rack-mount space
- The front and rear doors are perforated for maximum airflow into and out of the cabinet; the double door design uses less space in the aisle when opened
- Each cabinet includes two pairs of 19" EIA equipment mounting rails to provide front and rear support for the switch, equipment and shelves
- Cabinets are available in two heights and three depths to match site requirements

## APPLICATIONS

- The N-Series TeraFrame® Network Cabinet for the Cisco Nexus 7018 Switch lets you deploy the Cisco Nexus 7018 switch in hot aisle/cold aisle data center environments.
- Use the cabinet to support a mix of patch panels and fiber enclosures above the switch.

## USE WITH

- F-Series TeraFrame® Cabinets
- Caster Kit
- Front-To-Rear Cable Manager Kit
- Horizontal Furcation Bracket Kit
- Vertical Furcation Bracket
- Universal Accessory Rail Kit

## RELATED ACCESSORIES

- Universal Horizontal Cable Manager
- Jumper Trays
- Extra Heavy Duty Sliding Shelf
- Saf-T-Grip® Reusable Cable Management Straps



### Large Brush-Sealed Openings

Allow large quantities of cable to enter or exit the cabinet



### Network Switch Exhaust Duct

Converts side-to-side airflow to front-to-rear, allowing cabinet to be used in a hot aisle/cold aisle application



### Removable Doors and Side Panels

Doors and Side Panels can be removed to provide easy access to equipment and cables

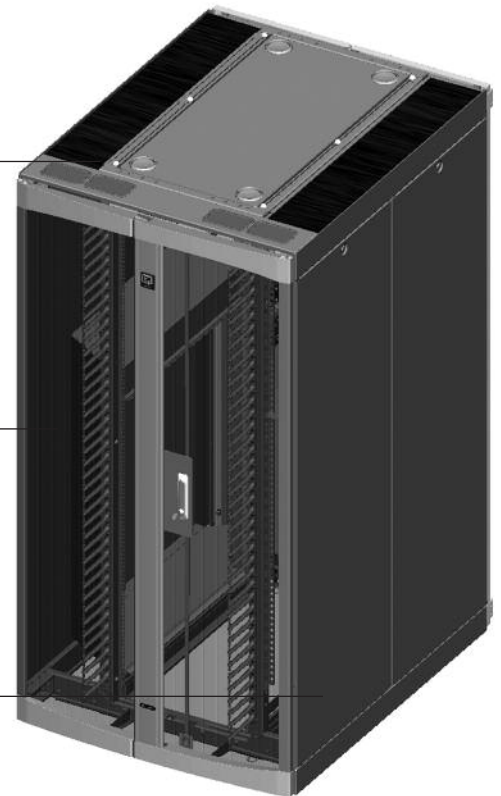

The N-Series TeraFrame® Network Cabinet for the Cisco Nexus 7018 Switch provides an engineered solution that meets the special installation requirements of the Cisco Nexus 7000 Series 18-slot switch.

The Cisco Nexus 7000 Series 18-slot switch (Nexus 7018) is a large, high-density modular network switch used in data centers to aggregate network connections from individual servers and top-of-rack or end-of-row switches. When fully configured, the switch can support 768 each 1-Gbps network connections or 512 each 10-Gbps network connections, weighs up to 684 pounds (311 kg) and can produce up to 56,300 BTU/hr (16.5 kW) of exhaust heat. The Nexus 7018 uses side-to-side airflow to cool I/O modules. Unobstructed airflow and a well defined cable pathway are critical to switch performance.

The N-Series TeraFrame Network Cabinet for the Cisco Nexus 7018 Switch features an internal 19 inch EIA four-post frame that supports the switch and offset side panels and doors that provide the required additional interior space for managing cables and airflow. An integrated Network Switch Exhaust Duct on the left side of the cabinet captures and guides hot exhaust air from the side of the switch to the rear door preventing the re-circulation of hot exhaust air through the switch. Plastic T-shaped Cable Management Fingers with openings that align with each rack-mount unit on the rack manage cables as they exit the I/O modules. A Front-To-Rear Cable Manager Kit routes cables front-to-rear along the side of the cabinet and large brush-sealed panels on the top of the cabinet allow cables to easily enter or exit the cabinet. The cabinet also features perforated double doors on the front and rear to provide front-to-rear airflow and minimize door swing into the aisles, and lighter two-piece side panels that make it easier to access the cabinet.

The N-Series TeraFrame Network Cabinet for the Cisco Nexus 7018 Switch is available in two heights and three depths to match site requirements. See inside for product details. Contact CPI Technical Support or visit the CPI Website ([www.chatsworth.com/configurator](http://www.chatsworth.com/configurator)) for configuration assistance.



**SPECIFICATIONS**

- Freestanding equipment cabinet engineered to support the Cisco Nexus 7018 switch
- Provides front and rear support for 19" W EIA rack-mount equipment and shelves
- For indoor use only, in environmentally controlled areas; may not be used outdoors, in harsh environments or in air-handling spaces
- Includes:
  - Welded and bolted steel and aluminum four-post frame
  - Equipment mounting rails, two pairs
  - Switch support brackets, one pair
  - Leveler feet and floor anchor brackets
  - Ground terminal block
  - Equipment mounting hardware
  - Network Switch Exhaust Duct with visor and diffuser
  - Cable Management Fingers Kit, two
  - Front-To-Rear Cable Manager Kit, one
  - Double, perforated front door with swing handle
  - Double, perforated rear door with swing handle
  - Two-point door latches with keyed or combination locks
  - Four-piece top panel
  - Two-piece, solid side panels (optional)
- Equipment space:
  - See Dimensions and Ordering Information
- Doors/latches:
  - Front door is curved, rear door is flat
  - Double doors (vertical split) minimize door swing
  - Door panels/inserts are perforated (79% open)
  - Doors have quick release hinge pins for easy removal
  - Each door has a swing handle and two-point latch
  - Choose keyed or combination/keyed locks
- Side panels:
  - Order with the cabinet or as a service part
  - Solid, two-piece panels with two recessed locking latches
  - Latches are keyed to match door locks
- Top panel:
  - Four-piece top panel: center panel and three perimeter panels (front and sides)
  - Center panel is solid with four 2.75" (70 mm) diameter grommet-protected holes
  - Front perimeter panel is solid with four 3.1" x 5.3" (79 mm x 135 mm) cable access ports
  - Side perimeter panels have 7.5"W (193 mm) brush-sealed openings that are 38.7"D (982 mm), 39.7"D (1008 mm) or 40.7"D (1033 mm) depending on cabinet depth
- Cable access/support:
  - Cabinet has an open base
  - Top panel has large brush-sealed side openings
  - T-shaped Cable Management Fingers on the front of the frame manage patch cords/jumpers entering/exiting the switch
  - Add up to three accessory Front-To-Rear Cable Manager Kits or Horizontal Furcation Bracket Kits per side to guide and secure cables as they enter or exit the cabinet
- Equipment support:
  - Two pairs of 19" W (482.6 mm) EIA-310-D equipment mounting rails in the cabinet
  - 1.75"H (44.45 mm) rack-mount units, marked and numbered on all rails
  - EIA-310-D Universal 5/8"-5/8"-1/2" (15.9 mm – 15.9 mm – 12.7 mm) vertical hole spacing
  - Threaded (tapped) or square-punched holes, square-punched holes use cage nuts
  - Front and rear rails are fixed in position 29.8" (756 mm) apart
  - Includes a support bracket for the Cisco Nexus 7018 switch which is mounted in the bottom (1U) location
  - Includes 50 each #12-24 screws with threaded rails or 25 each M6 cage nuts and screws with square punched rails
- Grounding/Bonding:
  - A Ground Terminal Block is included to attach the frame to ground
- Load capacity:
  - 2500 lb (1134.0 kg) static load on leveler feet
- Material:
  - Steel and aluminum extrusion frame, plastic cable managers
- Construction:
  - Welded and bolted frame, mounting rails bolt to frame
- Finish:
  - Epoxy-polyester hybrid powder coat paint in Black, Signature Blue, Glacier White or Steel Gray

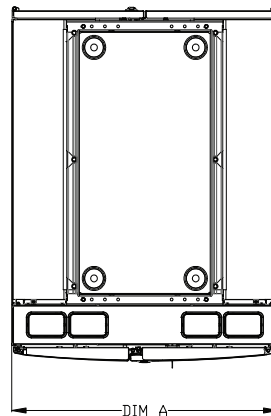
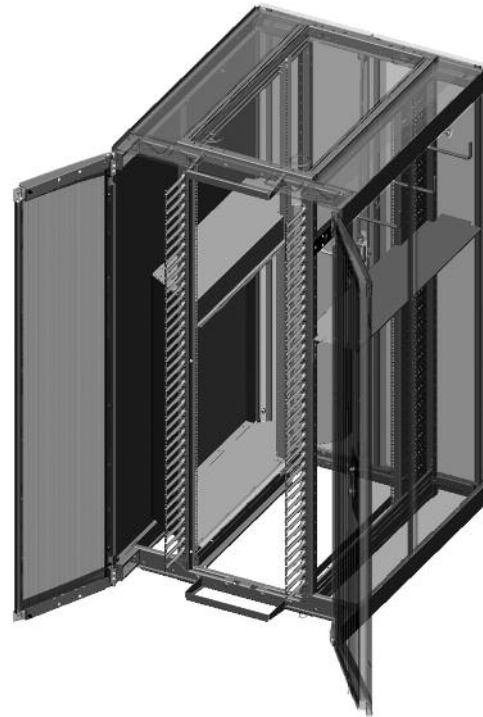

TOP PANEL VIEW

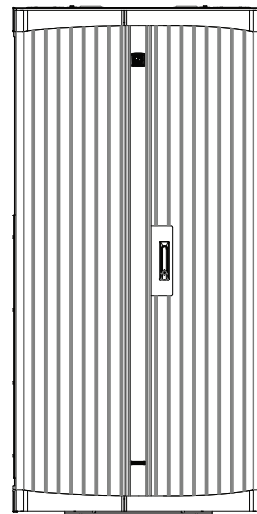
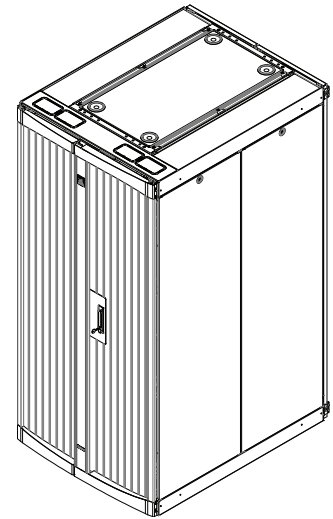

FRONT VIEW

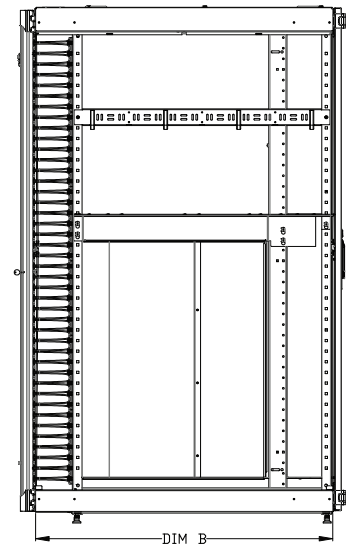

SIDE VIEW  
(SIDE PANELS REMOVED)

DIMENSIONS AND ORDERING INFORMATION

The N-Series TeraFrame® Network Cabinet for the Cisco Nexus 7018 Switch can be ordered in various sizes and configurations. Use the order matrix below to choose **Height**, **Depth**, **Rail Style**, **Front Door**, **Rear Door**, **Latch**, **Color**, **Top Panel** and **Side Panel Style**

**Example part number: NF5U-143C-C42**

<b>N</b>	<b>H</b>	<b>5</b>	<b>D</b>	<b>-</b>	<b>R</b>	<b>FD</b>	<b>RD</b>	<b>L</b>	<b>-</b>	<b>C</b>	<b>TP</b>	<b>SP</b>
----------	----------	----------	----------	----------	----------	-----------	-----------	----------	----------	----------	-----------	-----------

1. Height					
Cabinet		Frame		Rail	C
in	mm	in	mm	U	
78.3	1989	78.1	1984	42	
83.5	2122	83.4	2118	45	F

2. Side Exhaust Duct & Width			
Network Exhaust Duct		Width (Dim. A)	
		in	mm
Cisco Nexus 7018		40.0	1016
			5

3. Depth								
Cabinet		Rail (max.)		Frame		Cabinet Footprint (Dim. B)		R
in	mm	in	mm	in	mm	in	mm	
49.1	1247	29.8	756	39.4	1000	45.3	1150	
50.1	1272	29.8	756	40.4	1025	46.3	1175	T
51.1	1297	29.8	756	41.3	1050	47.2	1200	U

Note: When sizing to match standard TeraFrame, use the same part number digit for cabinet depth as the standard TeraFrame. The Cabinet Footprint does not include doors which add approximately 97 mm (3.8") of depth to the cabinet.

10. Side Panel Style	
0	None
1	Solid, Kit, 1 each
2	Solid, Kit, 2 each

Note: Each kit includes two panels and covers one side.

9. Top Panel	
4	Solid, 2 Large Brush Openings

8. Color	
C	Black
D	Signature Blue
E	Glacier White
F	Steel Gray

7. Latches (Door)	
C	Two-Point, Cam Latch, Keyed Lock
E	Two-Point, Cam Latch, Combination Lock

6. Rear Door	
3	Double, Perforated Metal

5. Front Door	
4	Double, Perforated Metal

4. Rail Style	
1	Square Punch, 2 Pair
2	Tapped, #12-24, 2 Pair

Notes:

1. Height: Two heights are available. The cabinet height is the overall height of the cabinet with a top panel. The frame height is the height of the internal frame without the top panel. Leveler feet add approximately 1 inch (25 mm) to the height of the cabinet. N-Series Cabinet and frame heights match F-Series TeraFrame® Cabinet System heights.
2. Side Exhaust Duct & Width: The cabinet includes a Network Switch Exhaust Duct sized for the Cisco Nexus 7018 switch. The duct is pre-installed to position the switch in the bottom 25U of the cabinet, but can be moved to match another mounting location. The cabinet also includes two Cable Management Finger Kits (T-shaped cable guides) which are pre-installed on the front of the internal frame on the right and left side. Overall cabinet width with side panels is 40.0 inches (1016 mm). The internal frame width is 23.6 inches (600 mm). The included mounting rails are 19 inches wide (482.6 mm) EIA-310-D compliant.
3. Depth: Three depths are available. The cabinet depth is the overall depth of the cabinet with doors. The frame depth is the depth of the internal frame. Rail depth is fixed at 29.8 inches deep (756 mm) by a pre-installed support bracket for the switch mounted in the 1U position. There is a 6 inch (152 mm) standoff at the front of the frame and 8.2 inch (208 mm) standoffs on each side of the frame. Doors add approximately 3.8 inches (97 mm) to overall depth. N-Series cabinet depths match F-Series TeraFrame Cabinet System depths.
4. Rail Style: Square-punched rails use snap-in cage nut hardware that can be changed to match equipment requirements. Tapped rails use screws. Order additional mounting hardware as required.
5. Latches: All doors have swing handles and a two point cam latch. The keyed lock includes a physical key. The combination lock has a programmable mechanical three-digit combination lock that is opened with three dials on the handle or with a key.

ORDERING INFORMATION



**Caster Kit**

Use the Caster Kit to move and position the cabinet before loading it with equipment. The kit includes a set of four casters and mounting brackets. Front casters are full swivel and rear casters are fixed. The Caster Kit attaches to the cabinet's internal frame and can be removed after the cabinet is set in place.

Part Number	Description	Shipping Weight lb (kg)
15537-001	Caster Kit, Black	45 (20.4)



**Horizontal Furcation Bracket Kit**

Use the Horizontal Furcation Bracket Kit to secure cable bundles in the space between the side panels and cabinet frame. The kit attaches to the cabinet frame above the Network Switch Exhaust Duct and visor. The bracket provides attachment points for the furcation plug on Corning Cable Systems Plug & Play Universal Systems trunk cables and tie points for securing cables. Attach any combination of up to three Front-To-Rear Cable Manager Kits and Horizontal Furcation Bracket Kits per side within the cabinet. The kit includes installation hardware. Match to the depth of the cabinet.

Part Number	Description in (mm)	Shipping Weight lb (kg)
15483-C01	For 49.1 Deep (1247) Cabinet	6 (2.7)
15483-C02	For 50.1 Deep (1272) Cabinet	6 (2.7)
15483-C03	For 51.1 Deep (1297) Cabinet	6 (2.7)

Color is black.



**Floor Installation Hardware**

Cabinets must be securely attached to the floor before loading with the switch and other equipment. This kit includes installation hardware for concrete slab floors (4 each, 3/8 inch anchors, stud bolts, flat washers and hex nuts). Other options are available.

Part Number	Description	Shipping Weight lb (kg)
40604-001	Installation Kit, Concrete Slab	1 (0.5)

Zinc-Plated



40605-001

**Equipment Mounting Hardware**

Attaches equipment and shelves to the cabinet. Use screws with tapped rails. Use cage nuts and screws with square-punched rails.

Part Number	Description	Shipping Weight lb (kg)
40605-001	Screws, #12-24, 50 Pk, Zinc	1 (0.5)
40605-005	Screws, #12-24, 50 Pk, Black	1 (0.5)
12637-001	Cage Nuts, Screws, M6, 25 Pk, Gold	1 (0.5)
12638-001	Cage Nuts, Screws, #10-32, 25 Pk, Zinc	1 (0.5)
12639-001	Cage Nuts, Screws, #12-24 25 Pk, Black	1 (0.5)



**Vertical Furcation Bracket**

Use the Vertical Furcation Bracket to secure cable bundles in the space between the side panels and cabinet frame. Use the bracket in the 51.1 inch deep (1297 mm) cabinet only. The bracket attaches to the cabinet frame. Locate the bracket on the right side behind the equipment mounting rail. The bracket provides attachment points for the furcation plug on Corning Cable Systems Plug & Play Universal Systems trunk cables and tie points for securing cables. The kit includes installation hardware. Match to the height of the cabinet.

Part Number	Description	Shipping Weight lb (kg)
34707-C02	For 42U Cabinet	11 (5.0)
34707-C05	For 45U Cabinet	12 (5.4)

Color is black. Use only in 51.1 inch deep (1297 mm) cabinets.



**Front-to-Rear Cable Manager Kit**

Use the Front-to-Rear Cable Manager Kit to create a front-to-rear cable pathway along the side of the cabinet in the space between the side panels and cabinet frame. The kit attaches to the cabinet frame above the Network Switch Exhaust Duct and visor. Each kit includes a support bracket and four 2.8 inch high by 7 inch deep (71 mm x 180 mm) U-shaped rings to support cables. The bracket includes tie points to secure cable bundles, and the rings can be repositioned to match support requirements. Attach any combination of up to three Front-To-Rear Cable Manager Kits and Horizontal Furcation Bracket Kits per side within the cabinet. The kit includes installation hardware. Match to the depth of the cabinet.

Part Number	Description in (mm)	Shipping Weight lb (kg)
15529-C01	For 49.1 Deep (1247) Cabinet	8 (3.6)
15529-C02	For 50.1 Deep (1272) Cabinet	9 (4.1)
15529-C03	For 51.1 Deep (1297) Cabinet	9 (4.1)

Color is black. One kit is included with each cabinet.



15482-C01

**Universal Accessory Rail Kit**

Use the Universal Accessory Rail Kit to provide additional vertical cable management for patch cords in the front corners of the cabinet. The kit attaches to the cabinet's front vertical frame uprights above the Network Switch Exhaust Duct and visor. The rail supports accessory 4 inches wide by 5.5 inches deep (102 mm x 140 mm) Swivel Cable Spools and Fiber Module Adapters in the space between the cabinet frame and the side of the cabinet and includes tie points to secure cable bundles. Accessory attachment points are spaced vertically every 0.88 inches (22.2 mm) to align accessories with rack-mount units in the cabinet. The rail is C-shaped, 0.8 inches wide by 1.6 inches deep (19 mm x 41 mm), made from steel and includes installation hardware. Match to the height of the cabinet.



34716-C01



34713-C01

Part Number	Description	Shipping Weight lb (kg)
15482-C01	For 42U Cabinet	3 (1.4)
15482-C02	For 45U Cabinet	3 (1.4)
34716-C01	Swivel Cable Spool, Each	2 (0.9)
34716-C02	Swivel Cable Spool Pack of 6	3 (1.4)
34713-C01	Fiber Module Adapter for Corning Cable Systems Plug & Play System, Universal Modules	2 (0.9)

Color is black.

SERVICE PARTS

Service parts include mounting rails, side panels, doors, door latches and baying kits and are used as replacement parts. Please contact CPI if you do not see the service part you need.

**Fixed Mounting Rails**

Replacement pair of equipment mounting rails for the front side of the N-Series TeraFrame Network Cabinet for the Cisco Nexus 7018 Switch. Mounting rails attach to the cabinet frame's vertical uprights and are not adjustable in depth. The rail minimizes interference with the Network Switch Exhaust Duct. Match to cabinet height.

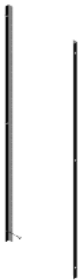

Part Number		Description	Shipping Weight lb (kg)
Square-Punched	Tapped #12-24		
34626-002	34667-002	For 42U Cabinet	13 (5.9)
34626-005	34667-005	For 45U Cabinet	14 (6.4)

Mounting rails are plated and silver colored. \*Shipping weights are for tapped rails.

**Equipment Mounting Rails (Rear)**

Replacement pair of equipment mounting rails for the rear side of the N-Series TeraFrame Network Cabinet for the Cisco Nexus 7018 Switch. Mounting rails attach to the side of the cabinet frame and can be adjusted in depth front-to-rear, but are fixed at 29.8 inches deep (756 mm) by a pre-installed support bracket for the switch mounted in the 1U position. Match to cabinet height.



Part Number		Description	Shipping Weight lb (kg)
Square-Punched	Tapped #12-24		
35009-002	35008-002	For 42U Cabinet	13 (5.9)
35009-005	35008-005	For 45U Cabinet	14 (6.4)

Mounting rails are plated and silver colored. \*Shipping weights are for tapped rails.

**Front Door**

Replacement front door for the N-Series TeraFrame Network Cabinet for the Cisco Nexus 7018 Switch. The door does not include a latch (see Front Door Latch Kit below). Match to the height and color of the cabinet.



Part Number	Description	Shipping Weight lb (kg)
15510-X01	For 42U Cabinet	52 (23.6)
15510-X02	For 45U Cabinet	54 (24.5)

X=Color: C=Black, D=Signature Blue, E=Glacier White, F=Steel Gray

**Rear Door**

Replacement rear door for the N-Series TeraFrame Network Cabinet for the Cisco Nexus 7018 Switch. The door does not include a latch (see Rear Door Latch Kit below). Match to the height and color of the cabinet.



Part Number	Description in (mm)	Shipping Weight lb (kg)
15520-X01	For 42U Cabinet	56 (25.4)
15520-X02	For 45U Cabinet	59 (26.8)

X=Color: C=Black, D=Signature Blue, E=Glacier White, F=Steel Gray

**Front Door Latch Kit**

Replacement front door latch kit for the N-Series TeraFrame Network Cabinet for the Cisco Nexus 7018 Switch. The kit includes a swing handle, latch bars, and a combination or keyed lock. Match to the height of the cabinet.



Part Number		Description	Shipping Weight lb (kg)
Keyed Lock	Comb. Lock		
15518-C01	15518-C09	For 42U Cabinet	6 (2.7)
15518-C05	15518-C11	For 45U Cabinet	6 (2.7)

Color is black. \*Shipping Weight is for Combination Lock.

**Rear Door Latch Kit**

Replacement rear door latch kit for the N-Series TeraFrame Network Cabinet for the Cisco Nexus 7018 Switch. The kit includes a swing handle, latch bars, and a combination or keyed lock. Match to the height of the cabinet.



Part Number		Description	Shipping Weight lb (kg)
Keyed Lock	Comb. Lock		
34513-C02	34579-C02	For 42U Cabinet	6 (2.7)
34513-C05	34579-C05	For 45U Cabinet	6 (2.7)

Color is black. \*Shipping Weight is for Combination Lock.

**Dual Side Panel Kit**

Replacement side panel kit for the N-Series TeraFrame Network Cabinet for the Cisco Nexus 7018 Switch. Each kit includes a two-piece (vertical split) side panel, a center support and key. Match to the height, depth and color of the cabinet.

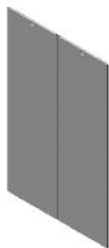

Part Number	Description in (mm)	Shipping Weight lb (kg)
15532-X02	For 42U x 49.1 Deep (1247) Cabinet	68 (30.8)
15532-X03	For 42U x 50.1 Deep (1272) Cabinet	69 (31.3)
15532-X04	For 42U x 51.1 Deep (1297) Cabinet	70 (31.8)
15532-X06	For 45U x 49.1 Deep (1247) Cabinet	71 (32.2)
15532-X07	For 45U x 50.1 Deep (1272) Cabinet	72 (32.7)
15532-X08	For 45U x 51.1 Deep (1297) Cabinet	73 (33.1)

X=Color: C=Black, D=Signature Blue, E=Glacier White, F=Steel Gray



**Baying Kit**

Use the Baying Kit to attach two N-Series TeraFrame Network Cabinets for the Cisco Nexus 7018 Switch together side-by-side. The kit includes hardware that connects cabinets at the corners. The cabinets must be the same height and depth. Cabinets can be bayed with or without side panels installed.

Part Number	Description	Shipping Weight lb (kg)
15480-001	(1) Baying Kit, Black	1 (0.5)

