

Installation Instructions

OnTrac Cable Tray

Safety Information



WARNING:

DO NOT USE AS A WALKWAY, LADDER, OR SUPPORT FOR PERSONNEL.
USE ONLY AS A MECHANICAL SUPPORT FOR CABLES, TUBING AND RACEWAY.

Intended Use

Install this tray only in a restricted service environment, such as a data center. Use indoors only, in environmentally controlled areas; do not use outdoors, or in harsh environments. Allow only qualified service personnel to install or use this tray.

Tools Required

- Cable Tray Cutting Tool (P/N 34839-001)
- 7/16" Socket Wrench
- Sand Paper (for removal of painted finish)

Recommended Tools:

- Any tools needed for mounting the tray should be identified before installation.
- A metal file may be used to chamfer rough edges after cutting tray.
- Handheld rotary sanding tools speed up paint removal.
- Marking tools for marking wire cut locations reduce mistakes and ease planning.
- Electric nut drivers reduce assembly time of fittings.
- A plumb bob or laser level may be used to verify effectiveness of mounting points.
- A level may be used to check consistency of tray runs.
- A vacuum may be useful for cleanup of metal and paint shavings.

Cutting Recommendations

- Use cable tray cutting tool P/N 34839-001 to cut tray wires. Use side action bolt cutter to prevent sharp wires from protruding past the cut intersection.
- Angle cuts beyond cross wire (See Offset Cut image below).
- Concentrate on making smooth, clean cuts to prevent sharp edges.
- Cut bottom wires first, in the order shown below, starting the first cut at ① and continuing in numerical order. (See Bottom cutting order image).
- Cut side wires next, starting at the top and working down (See Side cutting order image).
- Examine all cuts and smooth out any sharp edges.

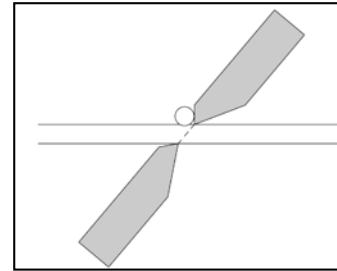

**Offset Cut
(Recommended)**

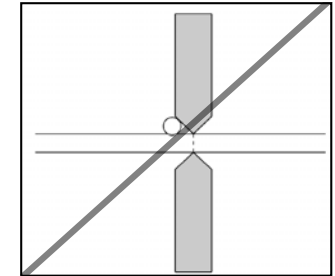

**Center cut blades are
NOT recommended**

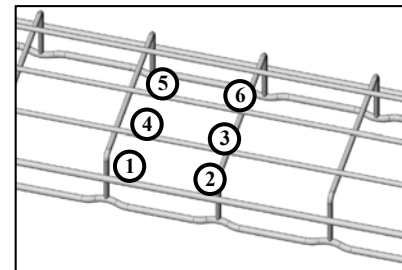

Bottom cutting order

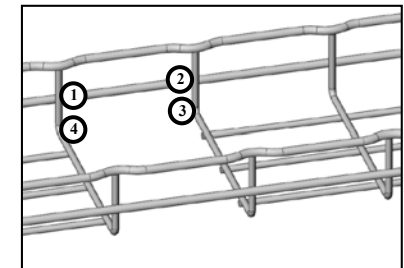

Side cutting order



CHATSWORTH PRODUCTS, INC.

IIS-734811, 01/06/10, Rev. 2, CPI/J Young

800-834-4969 (USA & Canada) • www.chatsworth.com • techsupport@chatsworth.com

For international phone numbers, see our website or contact CPI Tech Support.

This drawing contains proprietary and confidential information and is protected by U.S. and international law. Unauthorized reproduction, disclosure or use of the drawing or the information therein is expressly forbidden except as agreed to in writing by Chatsworth Products, Inc.

Installation Instructions

OnTrac Cable Tray

End-to-End Splicing

- Use Standard Splice Kit (P/N 34738-X01) to connect sections of wire mesh cable tray together end-to-end, at intersections and turns
- Refer to table below for the number of splices required to form an end-to-end connection. Standard Splices Kits are sold in packs of 50 splices. Quantities listed in table are for individual splices.
- Use two splices (one per side) on the sides of the 2"H (50 mm) tray and four splices (two per side) on the sides of the 4"H (100 mm) and 6"H (150 mm) trays; use the rest of the splices evenly spaced on the bottom of the tray.
- The two halves of the splice wrap around adjacent wires on the tray connecting the tray wires together.
- Always install bolt heads on the inside of the tray to protect cables.
- Electrical bonding of painted trays and connectors requires metal-to-metal contact between tray wires and the splice. Remove paint where the splices contact the trays.
- Cable tray employing these splice methods is suitable for use as an equipment grounding conductor.

P/N 34738-X01: Standard Splice

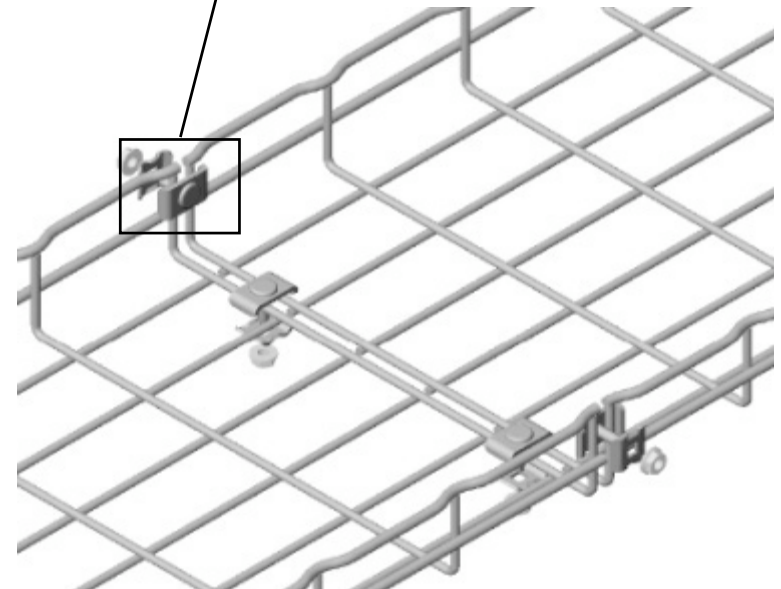
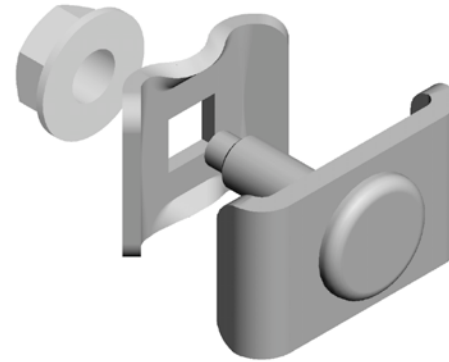

Number of Standard Splices Required to Form an End-to-End Connection

Tray Height	Tray Width							
	4" 100 mm	6" 150 mm	8" 200 mm	12" 300 mm	16" 400 mm	18" 450 mm	20" 500 mm	24" 600 mm
2" 50 mm	2	3	3	4	4	4	5	5
4" 100 mm	4	4	6	6	7	7	7	8
6" 150 mm	N/A	N/A	6	6	7	7	7	8

Installation Instructions

OnTrac Cable Tray

Alternate End-to-End Splicing Method

- Recommended for all trays that are 18"W (450 mm) or wider
- Use Splice Bar (P/N 34739-X01) with Standard Splice Kits (P/N 34738-X01) to create a more secure end-to-end connection between wire mesh cable tray sections. Splice Bars replace Standard Splices used on side of tray.
- Refer to table below for the number of Splice Bars required to form an end-to-end connection. Splice Bars are sold in packs of 50. Quantities listed in table are for individual splices.
- Use two splice bars (one per side) on the sides of the 2"H (50 mm) tray and four splice bars (two per side) on the sides of the 4"H (100 mm) and 6"H (150 mm) trays.
- Splice Bar attaches to the side of the tray using three Splice Washer & Bolts (P/N 34728-X01); 1/4" hardware
- Always install bolt heads on the inside of the tray to protect cables.
- Electrical bonding of painted trays and connectors requires metal-to-metal contact between tray wires and the splices. Remove paint where the splices contact the trays and splice bars.
- Cable tray employing these splice methods is suitable for use as an equipment grounding conductor.

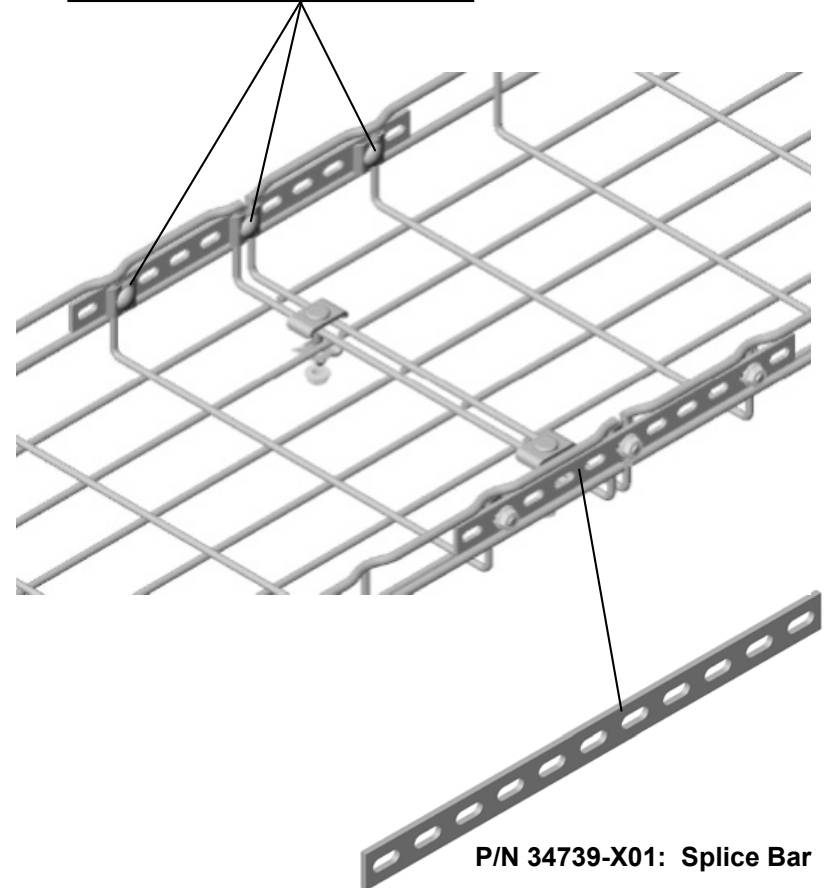
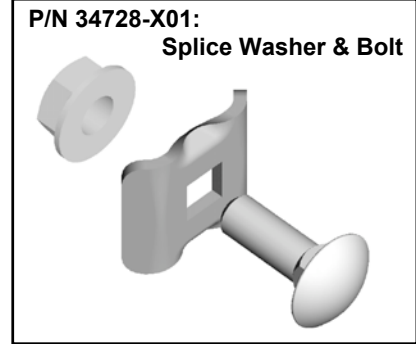

Number of Splice Bars Required for an End-to-End Connection					
Tray Height	Tray Width				
	12" 300 mm	16" 400 mm	18" 450 mm	20" 500 mm	24" 600 mm
2" 50 mm	2	2	2	2	2
4" 100 mm	4	4	4	4	4
6" 150 mm	4	4	4	4	4

Smooth 90° Turn

Installation Instructions

OnTrac Cable Tray

- Refer to the table below to determine how many tray sections will be required to be cut from the tray for the turn (See images on right for detail).
- Refer to table below for the number of hardware pieces required to form a smooth 90° turn. Splice Kit, Splice Bar and Splice Washer & Bolt Kit are sold in packs of 50. Quantities listed in this table are for individual splices/bars/washers.
- Make one splice connection between each removed section. One connection is made using a Splice Bar (P/N 34739-X01) and two Splice Washers & Bolts (P/N 34728-X01). The Splice Bar may be cut short with wire cutters for finished look. The rest of the connections use Standard Splices (P/N 34738-X01).
- Always install bolt heads on the inside of the tray to protect cables.
- Electrical bonding of painted trays and connectors requires metal-to-metal contact between tray wires and the splice. Remove paint where the splices contact the trays.
- Installing a ground conductor along fitting using P/N 34838-001 is required to insure bonding across removed sections (See page 8 for details).
- Cable tray employing these splice methods is suitable for use as an equipment grounding conductor.

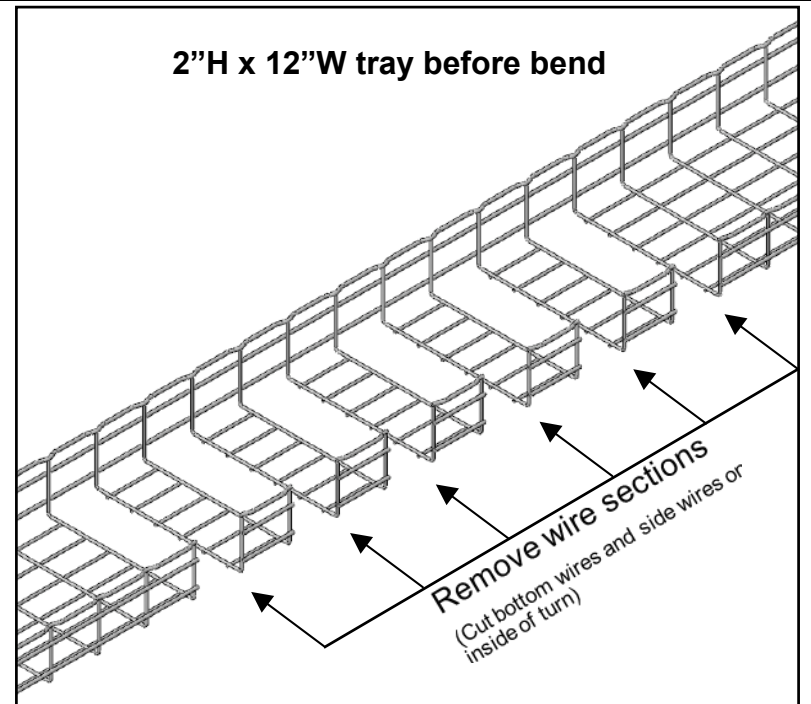

Smooth 90° Turn Forming Guide				
Tray Width	Removed Sections	Standard Splice Bolt P/N 34738-X01	Splice Bar P/N 34739-X01	Splice Washer and Bolt P/N 34728-X01
4" 100 mm	2	1	1	2
6" 150 mm	3	2	1	2
8" 200 mm	4	3	1	2
12" 300 mm	6	5	1	2
16" 400 mm	7	6	1	2
18" 450 mm	8	7	1	2
20" 500 mm	10	9	1	2
24" 600 mm	11	10	1	2

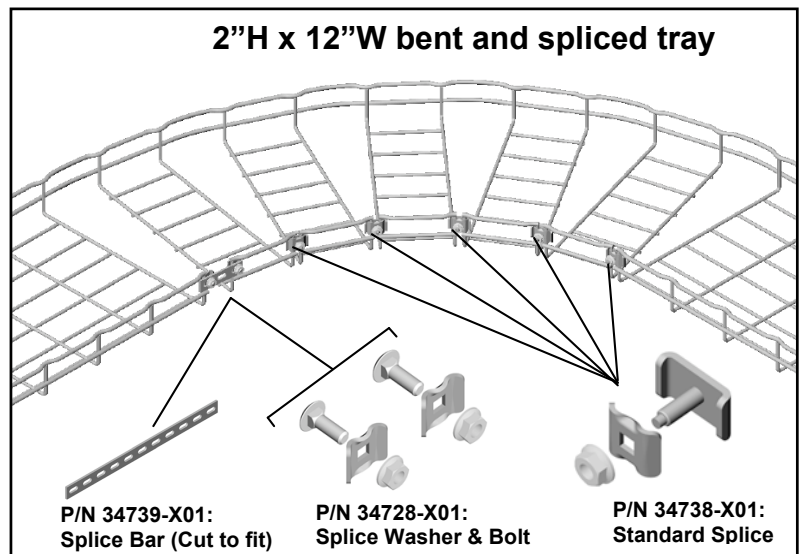

Tight 90° Turn

Installation Instructions

OnTrac Cable Tray

- Refer to the table to the right to determine how many tray sections will be required to be cut from the tray for the turn. Insure that the side wire cuts and the mid-section cuts are always symmetric (See cutting detail on the next page).
- Bend the tray 90° around the center of the cuts. Use the 90° Splice Bar Kit (P/N 34740-X01) to secure the fitting together. One 90° Splice Bar Kit comes with enough hardware for two turns (See 90° Splice Bar Kit detail to the right).
- Use the 90° Splice Bar with Splice Washers and Bolts to connect the inside side edges together. Use the Clamp Washers and Carriage Bolt to clamp the over lapping mesh together (See image below).
- Always install bolt heads on the inside of the tray to protect cables.
- Electrical bonding of painted trays and connectors requires metal-to-metal contact between tray wires and the splice. Remove paint where the splices contact the tray and 90° Splice Bar.
- Installing a ground conductor along fitting using P/N 34838-001 is required to insure bonding across removed sections (See page 8 for details).
- Cable tray employing these splice methods is suitable for use as an equipment grounding conductor.

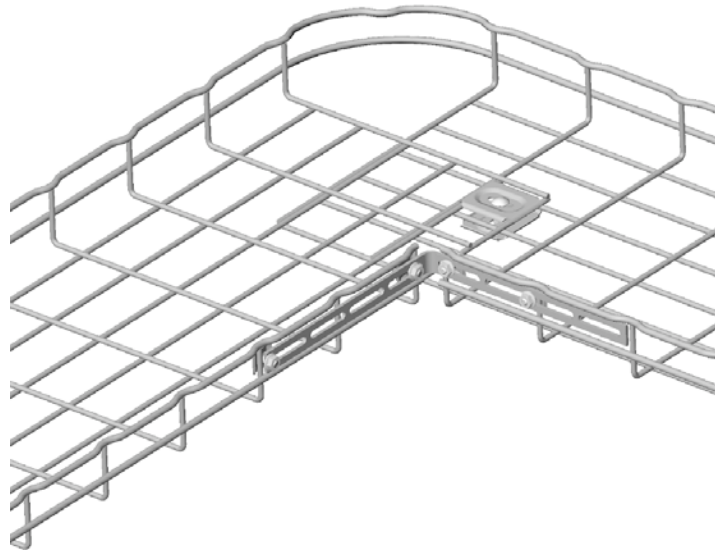

Tight 90° Turn Cut Detail: Top View (2"H x 12"W Tray Shown)

P/N 34740-X01: 90° Splice Bar Kit



x 8
Splice Washer and Bolt
(Secures 90° Splice bar
to tray)



x 2
Carriage Bolt
(Secures clamp
washers together)



x 4
Clamp Washer
(Clamps bottom tray
mesh together)



x 2
90° Splice Bar
(Secures inner side
edges of tray together)

Tight 90° Turn Forming Guide

Tray Width	Removed Mid-Sections	Removed Side Sections
4" 100 mm	1	3
6" 150 mm	1	5
8" 200 mm	2	4
12" 300 mm	2	6
16" 400 mm	2	8
18" 450 mm	2	8
20" 500 mm	2	10
24" 600 mm	2	10

Installation Instructions

OnTrac Cable Tray

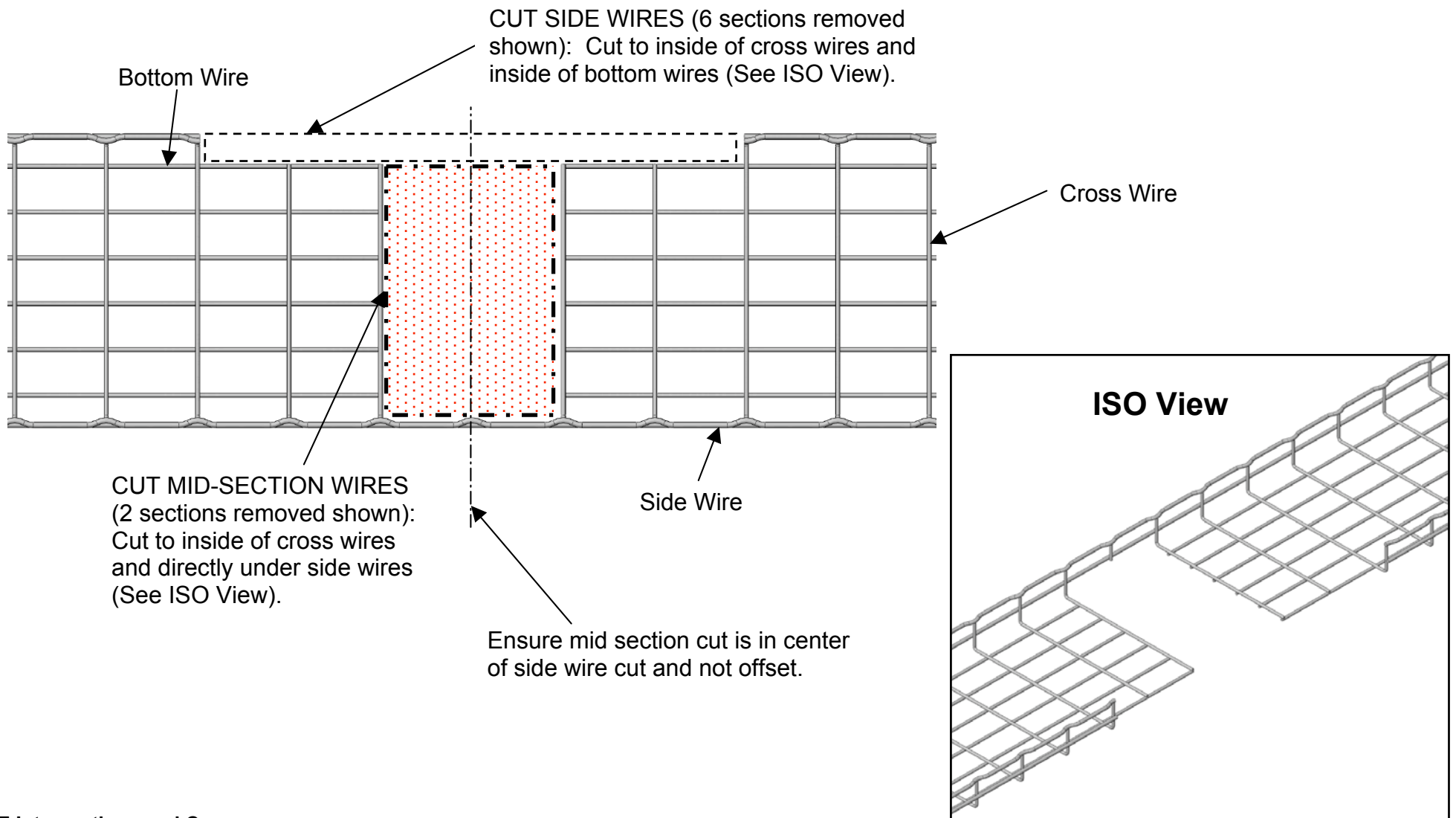

Installation Instructions

OnTrac Cable Tray

- Insure that the side wire cuts are wider than the width of the intersecting tray (See Continuous Tray cutting detail below).
- Use the 90° Splice Bar Kit (P/N 34740-X01) to secure the fitting together. One 90° Splice Bar Kit comes with enough hardware for one T fitting; you will need two kits for a tray cross over.
- To create a cross over, duplicate the T-fitting on the opposite side of the continuous tray.
- For extra strength you may cut the side wires from the tip of the intersecting tray and clamp the extra length to the bottom of the continuous tray. Clamp the mesh using clamp washers and carriage bolts; included in 90° Splice Bar Kit (See Terminating Tray images on bottom right for detail).
- Always install bolt heads on the inside of the tray to protect cables.
- Bonding of painted trays and connectors requires metal-to-metal contact between tray wires and the splice. Remove paint where the splices contact the tray and 90° splice bar.
- Installing a ground conductor along fitting using P/N 34838-001 is required to insure bonding across removed sections (See page 8 for details).
- The cable tray employing these splice methods is suitable for use as an equipment grounding conductor.

Terminating Tray

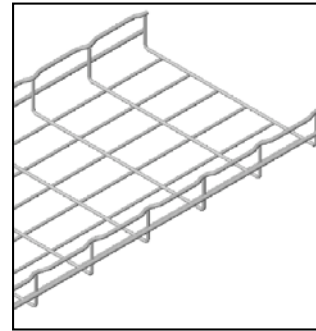

T-Intersection

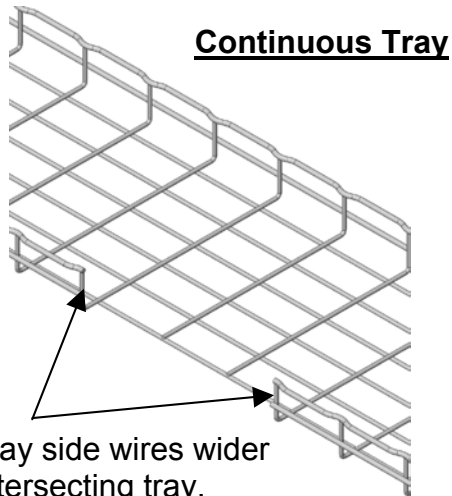
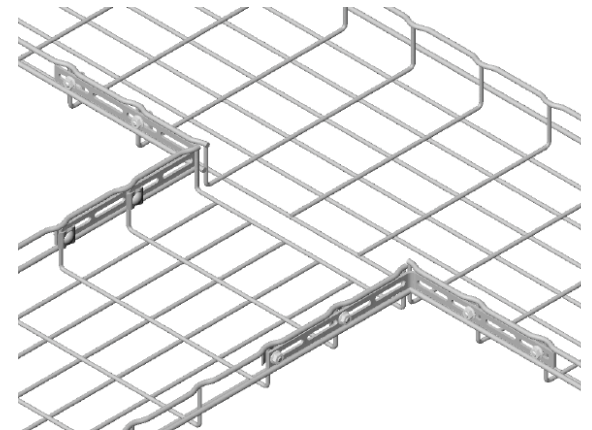

Best Practice Grounding

Terminating Tray (Cut for clamp washers)

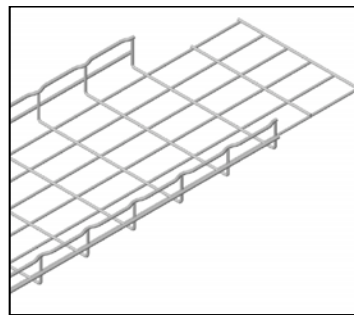

T-Intersection with clamp washers

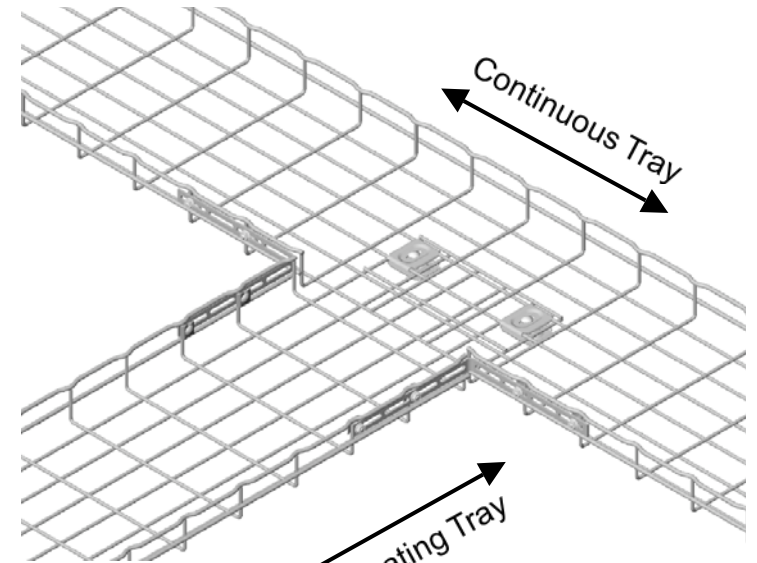

Ground Conductor Installed on Tight 90° Turn

Installation Instructions

OnTrac Cable Tray

- When properly spliced as indicated previously in this document, OnTrac cable tray and splice hardware will create a UL Classified equipment grounding pathway.
- Always install a grounding conductor across field cut fittings.
- Run a #6 AWG ground wire from a secure grounding point to the cable tray and use CPI P/N 34838-001 Split Bolt Grounding Clamp to attach the #6 AWG ground wire to OnTrac cable tray. Check to insure that a #6 AWG ground wire will be adequate for your application (See images on this page for detail).
- For painted trays ensure that there is metal-to-metal contact by removing the paint where the Split Bolt Grounding Clamp contacts the cable tray.

