

Product Information Sheet

RACK GROUND BAR KIT

The Rack Ground Bar Kit includes a thin strip of tinned copper that attaches to the rack's equipment mounting rail to provide direct ground contact for rack-mount equipment or a convenient bonding strip. Sized to fit a 7' (2.1 m) high rack with an EIA-310-D Universal hole pattern and 45 RMU, the ground bar is punched with a series of holes that align with each mounting hole on the rack. When equipment is mounted to the rack, the rack-mount brackets touch the ground bar. Alternately, the Equipment Ground Jumper Kit can be used to connect equipment to the grounding bar.

- Each kit includes one ground bar, three #12-24 zinc-plated thread forming hex washer head installation screws, an abrasive pad, joint compound and a ground label
- The ground bar is .05" (1.3 mm) thick tinned copper strip, .68" (17 mm) wide x 78.65" (1997 mm) high and is punched with holes that match the EIA-310-D Universal Hole Pattern
- Ground Bar is UL Listed

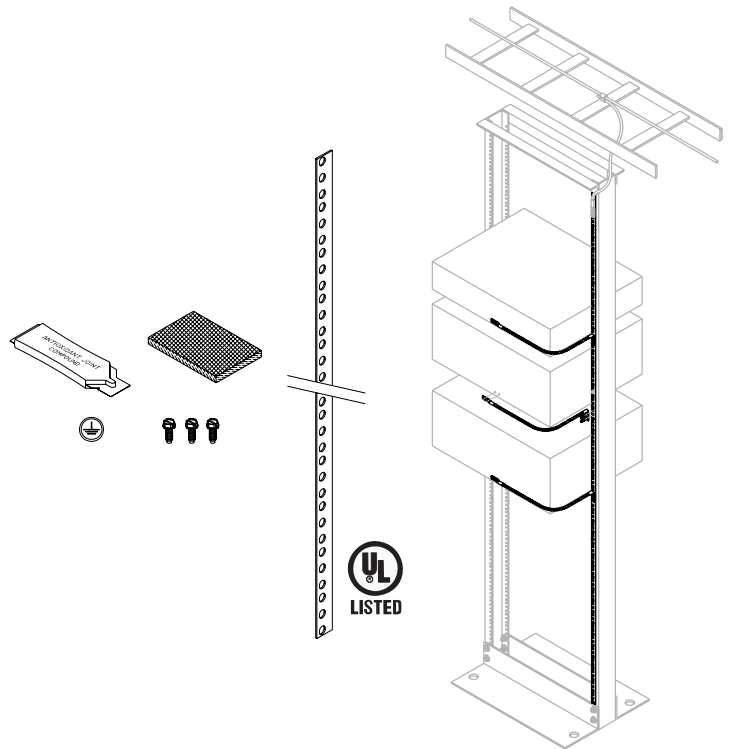

Part Number	Description	Shipping Weight
40172-001	Rack Ground Bar Kit	2 lb (0.9 kg)

800-834-4969 in U.S. & Canada • www.chatsworth.com



CHATSWORTH PRODUCTS, INC.

©2008 Chatsworth Products, Inc. All rights reserved. CPI, Saf-T-Grip, Seismic Frame, SlimFrame and MegaFrame are federally registered trademarks of Chatsworth Products, Inc. CPI Passive Cooling, Cube-iT Plus, Evolution, Simply Efficient, TeraFrame and QuadraRack are trademarks of Chatsworth Products, Inc. All other trademarks belong to their respective companies. 07/08