

17" LCD KVM DRAWER

KEY FEATURES

- Combination rack-mount LCD panel, keyboard and touchpad drawer
- For 19" EIA cabinets, uses only 1U of rack-mount space
- Single or dual rail models; dual rail model allows the display to remain open when the keyboard tray is closed
- 17" industrial TFT LCD display
- US or UK keyboard layouts with integrated touchpad
- Supports VGA video connection and PS/2 or USB keyboard and mouse connections
- Also available with an integrated KVM Switch

APPLICATIONS

- Provide a single set of rack-mount peripherals for accessing computer equipment in four-post racks and cabinets
- Combine with a KVM switch to access multiple computers

USE WITH

- CPI Cabinet Systems
- CPI 4-Post Rack Systems
- KVM Switches

RELATED ACCESSORIES

- Power Distribution Units (PDUs)
- Electronic Locking System (ELS)
- Remote Infrastructure Management (RIM-600) System

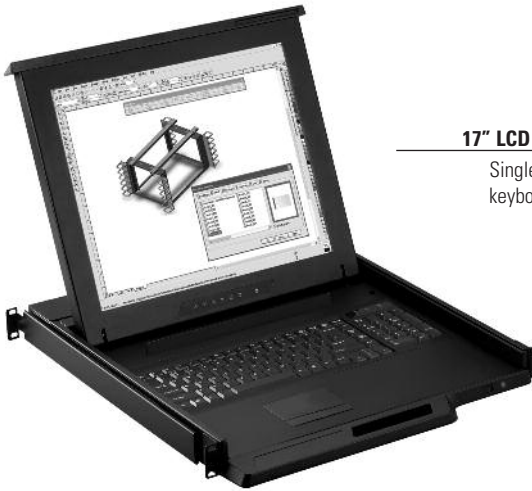

17" LCD KVM Drawer, Single Rail

Single rail laptop style display and keyboard.

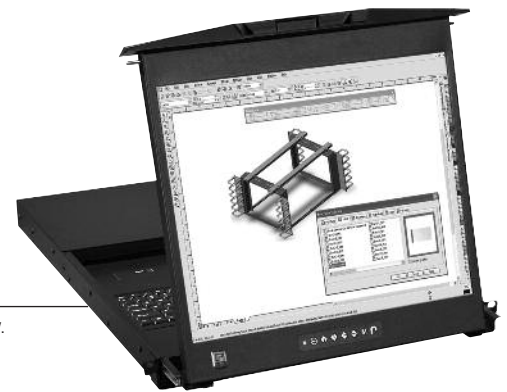

17" LCD KVM Drawer, Dual Rail

Display and keyboard open separately.

The 17" LCD KVM Drawer is a combination LCD flat panel display, keyboard and touchpad console that uses only 1U of rack-mount space. Use the space-saving 17" LCD KVM Drawer in 4-post racks and cabinets to provide easy access to rack-mount computer equipment.

The 17" LCD KVM Drawer includes a 17" TFT LCD color display, a full size keyboard with separate number pad and an integrated touchpad. Both US and UK keyboard layouts are available. The drawer has a single HD15 connector and includes a Combo KVM Cable with connections for VGA video and PS/2, as well as USB keyboard and mouse, to connect equipment. The display supports a wide range of resolutions to match most PC, MAC, SUN, IBM, HP and Dell computers. A wide viewing angle and good contrast create a crisp, clear image.

Two drawer styles are available: single and dual rail. The single rail model features a laptop-style design where the keyboard and panel are hinged and the LCD panel pivots open. On the dual rail model, the keyboard tray and panel are separate, which allows the LCD panel to be left in the open position when the keyboard tray is closed.

The 17" LCD KVM Drawer is part of a complete solution that includes KVM Switches which provide access to multiple computers from a single set of peripherals.

See reverse for product selection. Contact CPI Technical Support for configuration assistance. The Technical Support Team assists customers and partners to solve IT infrastructure problems in a timely and accurate manner by understanding their requirements and creating practical and suitable CPI Solutions.

SPECIFICATIONS

- Combination rack-mount LCD flat panel monitor, keyboard and touchpad console
- For indoor use only, in environmentally controlled areas; may not be used outdoors, in harsh environments or in air-handling spaces
- Dimensions:
 - Single-Rail: 1.73"H x 17.4"W x 18.1"D (44 mm x 442 mm x 460 mm)
 - Dual-Rail: 1.73"H x 17.4"W x 25.6"D (44 mm x 442 mm x 650 mm)
- Rack-Mount Size:
 - 1U x 19"EIA
- 17" LCD monitor with TFT color display
- US or UK keyboard layout
- Integrated touchpad
- Compatibility: Multi-platform, PC, MAC, SUN, IBM, HP and Dell
- Display specifications:
 - Brightness (cd/m²): 250
 - Color Support: 16.7 M
 - Contrast Ratio (typ.): 1000:1
 - Viewing Angle (H/V): 160° x 160°
 - Display Area (mm): 338 x 270
 - Dot pitch (mm): 0.264
 - Tr Response Tim (ms): 5
 - LCD Panel MTBF (hrs): 50,000
 - VGA Signal Input: Analog RGB, 0.7Vp-p
 - Sync. Type: Separate H/V, Composite, SOG
- Supports Screen Resolutions:
 - 720 x 400, 70 Hz
 - 640 x 480, 60/70/72/75 Hz
 - 800 x 600, 60/70/72/75 Hz
 - 1024 x 768, 60/70/75 Hz
 - 1152 x 864, 60/70/75 Hz
 - 1280 x 720, 60/70/75 Hz
 - 1280 x 1024, 60/70/72/75 Hz
- Input Connector:
 - (1) HD15, 15-pin connector
- Electrical:
 - Power Input: Auto-sensing 100 to 240 VAC, 50/60 Hz
 - Power Consumption: Max. 48 Watt, Standby 5 Watt
 - Power Inlet: (1) IEC60320 C-14
- Environmental:
 - Operation: 32-122°F (0-50°C)
 - Storage: 23-140°F (-5-60°C)
 - Operating Realtime Humidity: 20%-90%, non-condensing
 - Storage Relative Humidity: 5%-90%, non-condensing
 - Shock: 10G acceleration (11 ms duration)
 - Vibration: 5-500Hz 1G RMS random vibration
- Regulation Approval:
 - FCC, CE (all)
- Includes Rack/Cabinet Mounting Brackets:
 - Requires four-point (front/rear) support
 - Single-Rail maximum front/rear depth is 29.5" (749 mm); minimum front/rear depth is 19" (482 mm)
 - Dual-Rail maximum front/rear depth is 35.5" (900 mm); minimum front/rear depth is 21.5" (546 mm)
- Includes Cables:
 - (1) 6'L (1.8 m) IEC60320 C-13 to NEMA 5-15P power cord
 - (1) 6'L (1.8 m) HD15 to VGA/PS2/USB Combo KVM Cable
- Finish: Black only

SYSTEM DIAGRAM

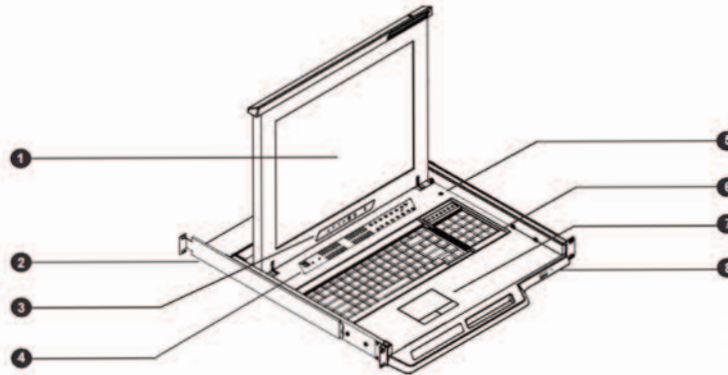

- | | |
|---|---|
| <ul style="list-style-type: none"> 1. 17" LCD TFT Display 2. Rack-Mount Rails 3. LCD Adjustment Buttons 4. KVM Switch Buttons | <ul style="list-style-type: none"> 5. Micro switch for screen auto power off 6. Keyboard and number pad 7. Touchpad 8. Blue LED, Power On Indicator |
|---|---|
- (only on models with KVM Switch)

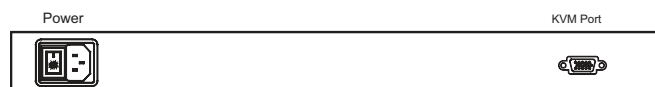

Back view – CPI P/N 37200-111, 37200-112, 37201-111 and 37201-112.

ORDERING INFORMATION

Part Number		Description	Shipping Weight lb (kg)
US Keyboard	UK Keyboard		
37200-111	37200-112	Single Rail LCD KVM Drawer	37 (16.8)
37201-111	37201-112	Dual Rail LCD KVM Drawer	43 (19.5)

Note: The US and UK keyboards have the same keys, but locations of some symbol keys (@, ~, \, |, #) are different. Additionally, the UK keyboard includes a key for the Pound symbol (£). The part numbers listed above do not include a KVM switch.



CABLE DIAGRAM

The included Combo KVM Cable has connections for VGA monitor and PS/2 or USB keyboard and mouse and can connect to a single server or a standalone KVM switch.

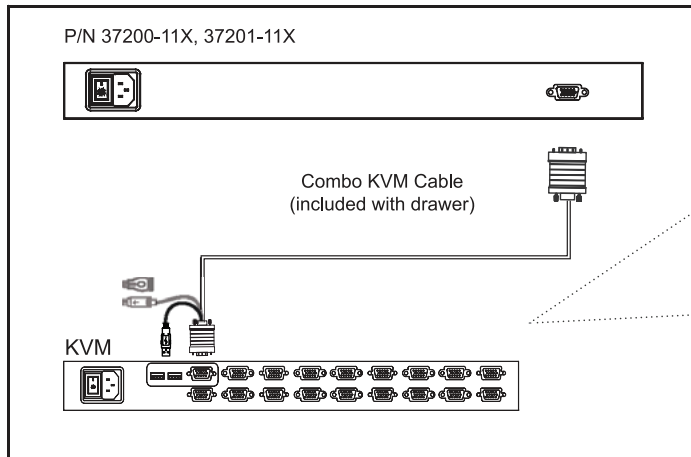

Connection to standalone KVM Switch (or Server) with USB keyboard and mouse.

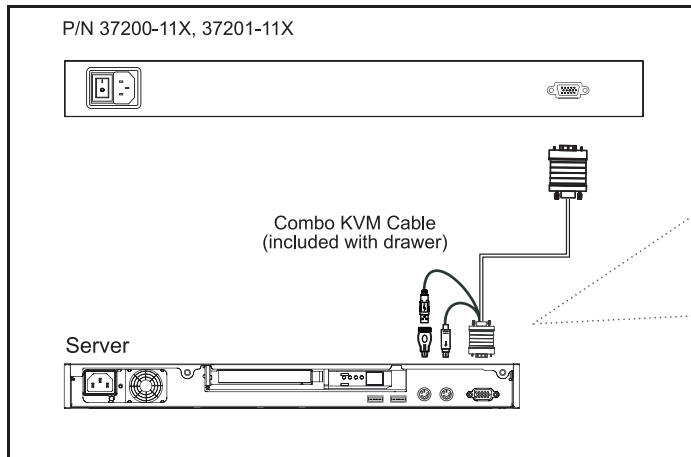

Direct connection to Server (or standalone KVM switch) with PS/2 keyboard and mouse.