

CHATSWORTH PRODUCTS, INC.

QUADRA-RACK

DES. J. ROBERSON

JOB NO. 11-1131

DATE 6/19/12

SHEET

1

OF **2** SHEETS

SEISMIC ANCHORAGE

CONCRETE SLAB

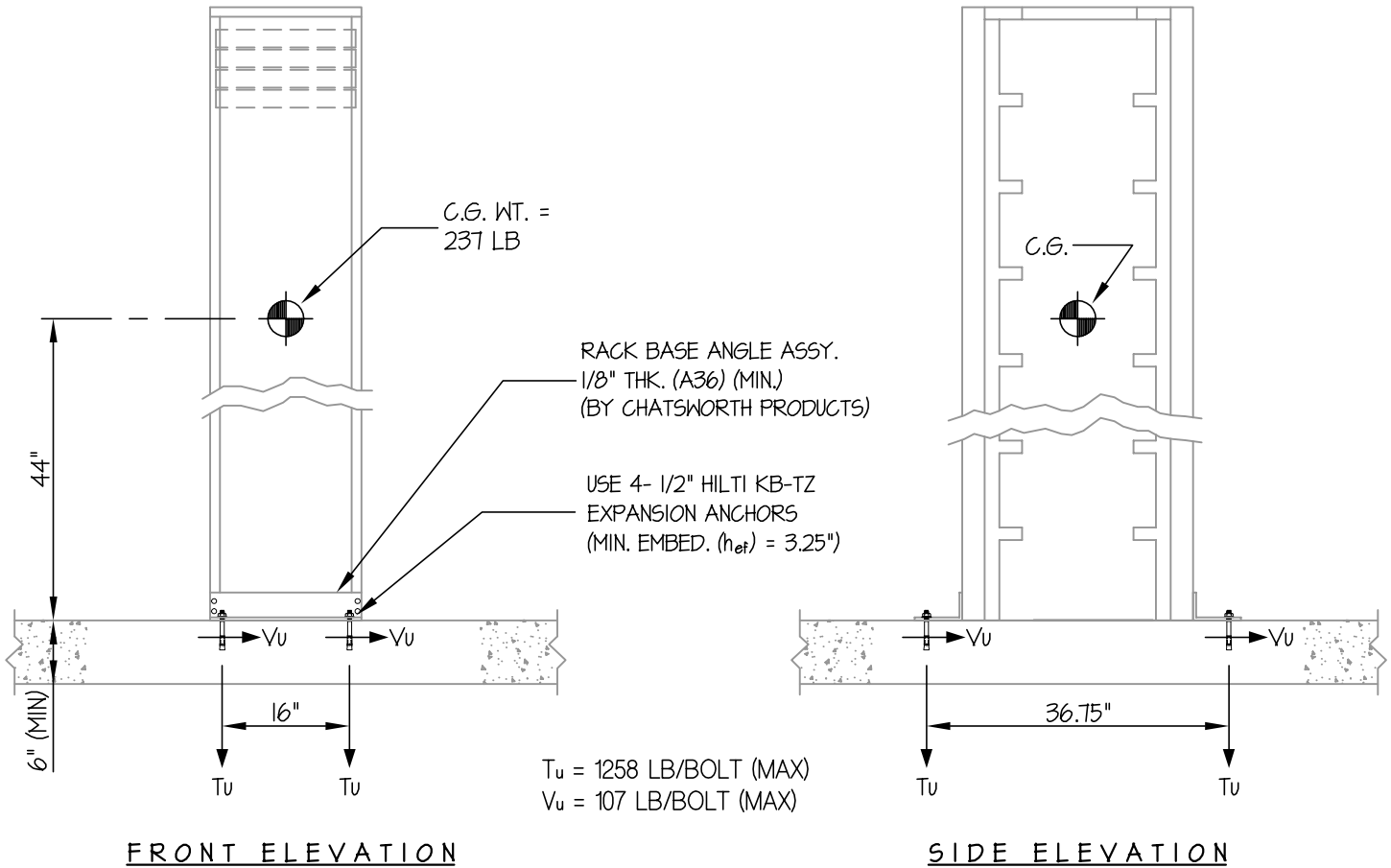

NOTES:

1. FORCES ARE DETERMINED PER 2010 CALIFORNIA BUILDING CODE AND ASCE 7-05 STRENGTH DESIGN IS USED.

HORIZONTAL FORCE (E_h) = $0.90 W_p (S_{ds} = 2.00, a_p = 2.5, I_p = 1.5, R_p = 6.0, z/h = 0.0)$

VERTICAL FORCE (E_v) = $0.40 W_p$

2. CENTER OF GRAVITY (C.G.) WEIGHT IS A MAXIMUM. THIS PRE-APPROVAL ENCOMPASSES ALL WEIGHTS UP TO THE MAXIMUM WEIGHT SHOWN.

3. STRUCTURAL ENGINEER OF RECORD SHALL PROVIDE SUPPORT STRUCTURE TO SUPPORT WEIGHTS AND FORCES SHOWN.



CHATSWORTH PRODUCTS, INC.

QUADRA-RACK

DES. J. ROBERSON

JOB NO. 11-1131

DATE 6/19/12

SHEET

2

OF **2** SHEETS

SEISMIC ANCHORAGE

CONCRETE SLAB

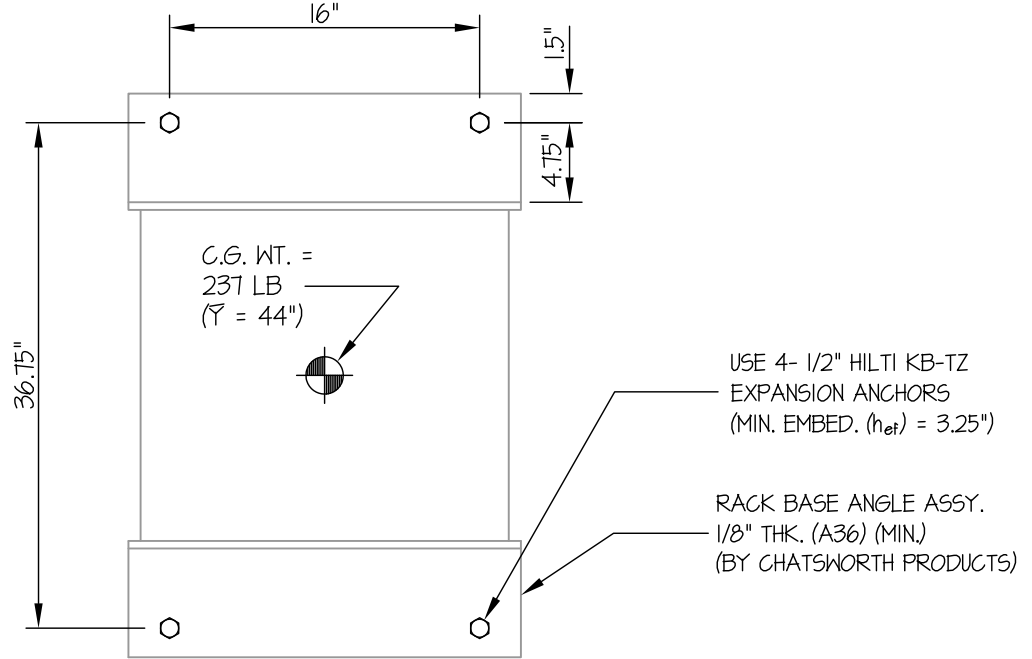

PLAN VIEW

LOADS: PER 2010 CALIFORNIA BUILDING CODE AND ASCE 7-05

(STRENGTH DESIGN IS USED) ($S_{ds} = 2.00$, $a_p = 2.5$, $I_p = 1.5$, $R_p = 6.0$, $z/h = 0.0$)

WEIGHT = 237 LB

HORIZONTAL FORCE (E_h) = $0.90W_p = 213$ LB

VERTICAL FORCE (E_v) = $0.40W_p = 95$ LB

BOLT SPECS: 1/2" ϕ HILTI KB-TZ

$\phi T = 0.75 \phi N_n = 2396$ LB/BOLT (TENSION)

$\phi V = 0.75 \phi V_n = 3232$ LB/BOLT (SHEAR)

BOLT FORCES:

TENSION (T)

$$T_{U \text{ MAXIMUM}} = \left[\frac{213\#(44")}{2\text{BOLTS}(36.75")} \times (0.3) \right] + \frac{213\#(44")}{2\text{BOLTS}(16")} - \frac{237\#(0.9) - 95\#}{4\text{BOLTS}} = 302 \text{ LB/BOLT (MAX)}$$

(HORIZ - SIDE TO SIDE) (HORIZ - FRONT TO BACK) (WEIGHT (0.9) - E_v)

SHEAR (V) (ASSUMES HALF THE NUMBER OF BOLTS)

$$V_{U \text{ MAXIMUM}} = \frac{213\#}{2\text{BOLTS}} = 107 \text{ LB/BOLT (MAX)}$$

PRying

$$M_{\text{PRying}} = 302\#(4.75") = 1435"\#$$

$$T_{\text{PRying}} = 1435"\#/1.5" = 957"\#$$

$$T_{\text{MAX}} = 957"\# + 302\# = \underline{1258 \text{ LB/BOLT (MAX)}}$$

UNITY CHECK:

$$\left(\frac{T_U}{\phi T} \right) + \left(\frac{V_U}{\phi V} \right) \leq 1.2 \quad \left(\frac{1258}{2396} \right) + \left(\frac{107}{3232} \right) = 0.56 \leq 1.2 \quad \therefore \text{OK}$$

CHATSWORTH PRODUCTS, INC.

QUADRA-RACK

DES. **J. ROBERSON**

JOB NO. **11-1131**

DATE **6/19/12**

SHEET

1

OF **2** SHEETS

SEISMIC ANCHORAGE

CONCRETE SLAB ON METAL DECK

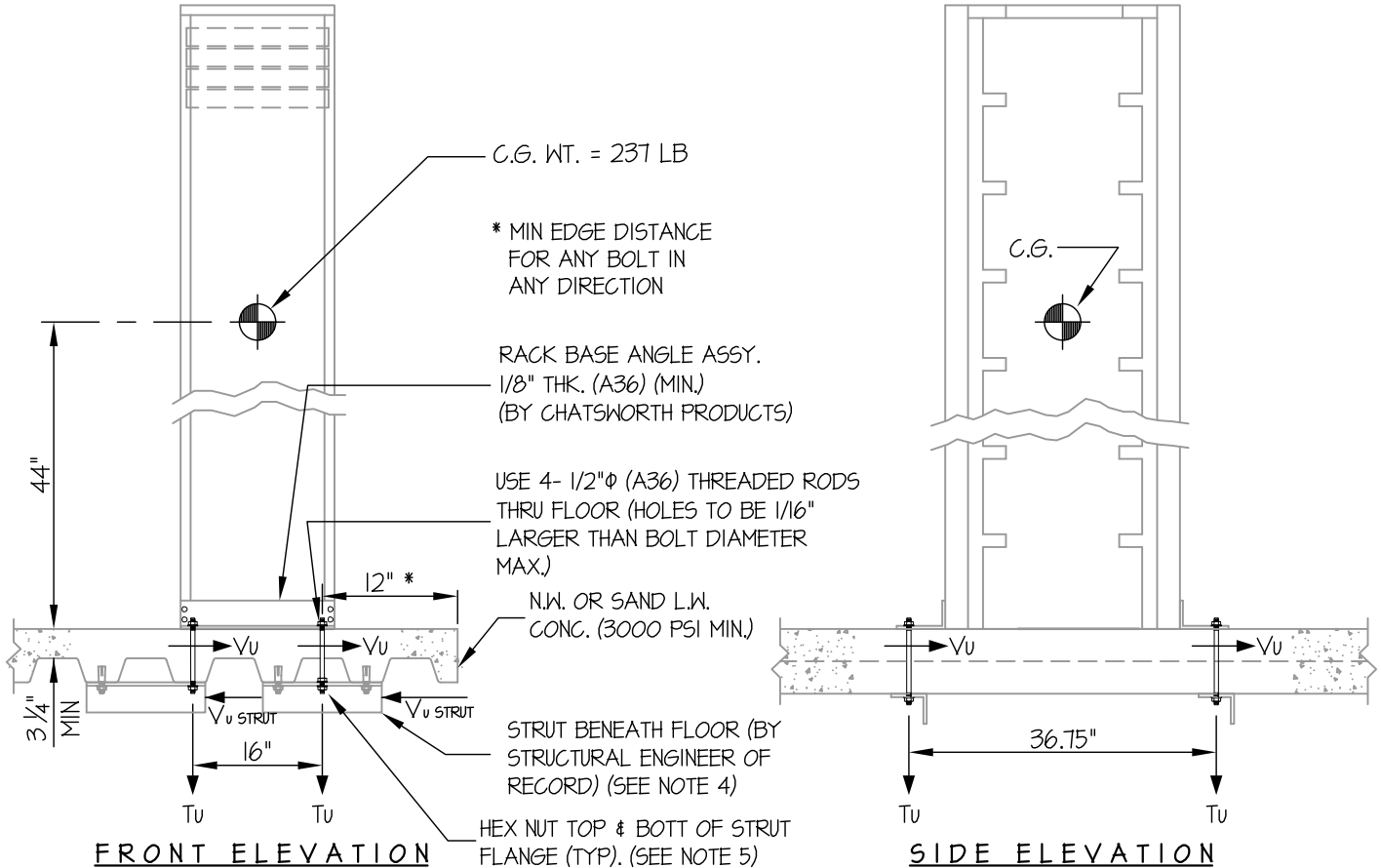

NOTES:

1. FORCES ARE DETERMINED PER 2010 CALIFORNIA BUILDING CODE AND ASCE 7-05 STRENGTH DESIGN IS USED.

HORIZONTAL FORCE (E_h) = 150 W_p ($S_d_s = 2.00$, $a_p = 2.5$, $I_p = 15$, $R_p = 6.0$, $z/h \leq 10$)

VERTICAL FORCE (E_v) = 0.40 W_p

$T_u = 2179$ LB/BOLT (MAX)
 $V_u = 89$ LB/BOLT (MAX)

2. CENTER OF GRAVITY (C.G.) WEIGHT IS A MAXIMUM. THIS PRE-APPROVAL ENCOMPASSES ALL WEIGHTS UP TO THE MAXIMUM WEIGHT SHOWN.

3. STRUCTURAL ENGINEER OF RECORD SHALL PROVIDE STRUCTURE TO SUPPORT WEIGHTS AND FORCES SHOWN.

4. STRUCTURAL ENGINEER OF RECORD SHALL DESIGN THE STRUT(S) AND ITS ATTACHMENTS TO RESIST A LOAD NOT LESS THAN $V_{u,STRUT}$ IN COMBINATION WITH ALL OTHER LOADS THAT MAY BE PRESENT, WHERE $V_{u,STRUT} = 0.6V_{u,MAX} \times$ (NO. OF ANCHORS ENGAGED BY STRUT) (MIN)

5. AT CONDITIONS WHERE NUT CANNOT BE PROVIDED AT TOP SIDE OF STRUT, PROVIDE TAPPED HOLE THROUGH STRUT FLANGE.

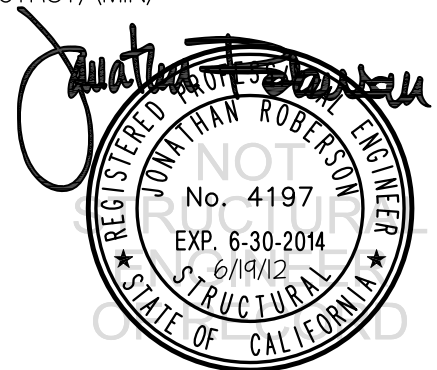

CHATSWORTH PRODUCTS, INC.

QUADRA-RACK

DES. J. ROBERSON

JOB NO. 11-1131

DATE 6/19/12

SHEET

2

OF **2** SHEETS

SEISMIC ANCHORAGE

CONCRETE SLAB ON METAL DECK

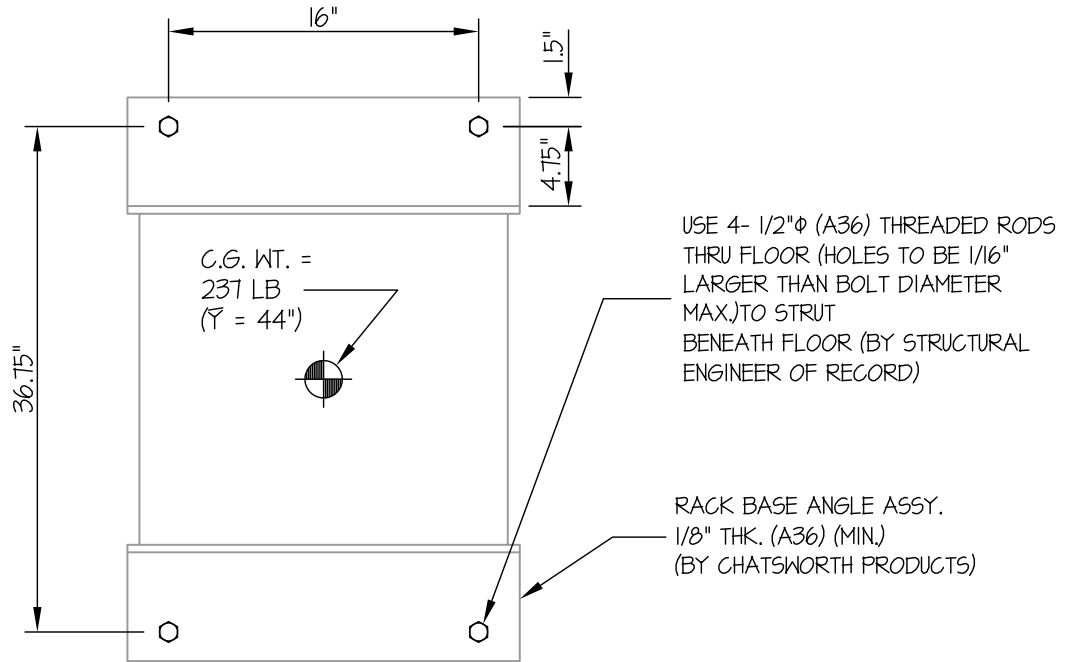

PLAN VIEW

LOADS: PER 2010 CALIFORNIA BUILDING CODE AND ASCE 7-05

(STRENGTH DESIGN IS USED) ($S_Ds = 2.00$, $a_p = 2.5$, $I_p = 1.5$, $R_p = 6.0$, $z/h \leq 1.0$)

WEIGHT = 237 LB

HORIZONTAL FORCE (E_h) = $1.50W_p = 356$ LB

VERTICAL FORCE (E_v) = $0.40W_p = 95$ LB

BOLT FORCES:

BOLT SPEC: 1/2" ϕ (A36) THREADED ROD

$\phi T = 6610$ LB/BOLT

$\phi V = 3530$ LB/BOLT

TENSION (T)

$$T_{U \text{ MAXIMUM}} = \left[\frac{356\#(44")}{2\text{BOLTS}(36.75")} \times (0.3) \right] + \frac{356\#(44")}{2\text{BOLTS}(16")} - \frac{237\#(0.9) - 95\#}{4\text{BOLTS}} = 523 \text{ LB/BOLT (MAX)}$$

(HORIZ - SIDE TO SIDE) (HORIZ - FRONT TO BACK) (WEIGHT (0.9) - E_v)

SHEAR (V)

$$V_{U \text{ MAXIMUM}} = \frac{356\#}{4\text{BOLTS}} = 89 \text{ LB/BOLT (MAX) (PER AISC J3.7, LESS THAN 20% STRESS)}$$

PRYING

$$M_{\text{PRYING}} = 523\#(4.75") = 2484"\#$$

$$T_{\text{PRYING}} = 2485"\#/1.5" = 1657"\#$$

$$T_{\text{MAX}} = 1657"\# + 523\# = \underline{\underline{2179 \text{ LB/BOLT (MAX)}}$$