

# Installation Instructions

## REAR DOUBLE DOOR

### Installation Notes



**CAUTION:** When mounting the doors, be sure to insert the hinge pins. If the hinge pins are not inserted, the doors could fall off the next time they are opened.

Bonding jumper wires, bonding connection points, and attaching hardware are provided for electrically bonding the doors to the cabinet frame. Quick-connect tabs are located on the inner surface of both rear doors near the bottom hinges. These tabs should be used for electrically bonding both doors to the cabinet frame by plugging the quick-connect end of the bonding jumper wires onto the quick-connect tabs on the doors.

### Included Hardware:

M6X16mm FH Screw (8 ea.)

M6X12mm PH Screw (2 ea.)

### Tools Required:

#2 Phillip screw driver

### Assembly Notes:

The hinges have a notch feature that prevents them from engaging unless the door is perpendicular to the cabinet. The door is perpendicular to the cabinet when it is parallel with the side of the cabinet.

### Assembly Sequence:

1. Attach the hinges to each side of the frame using two M6 flat head screws per hinge (Fig.1).
2. For the bonding jumper wire, use an M6 pan head screw to attach the end with the ring terminal to the frame threaded insert nearest to the bottom door hinge. Orient ring terminal as shown (Fig.1).

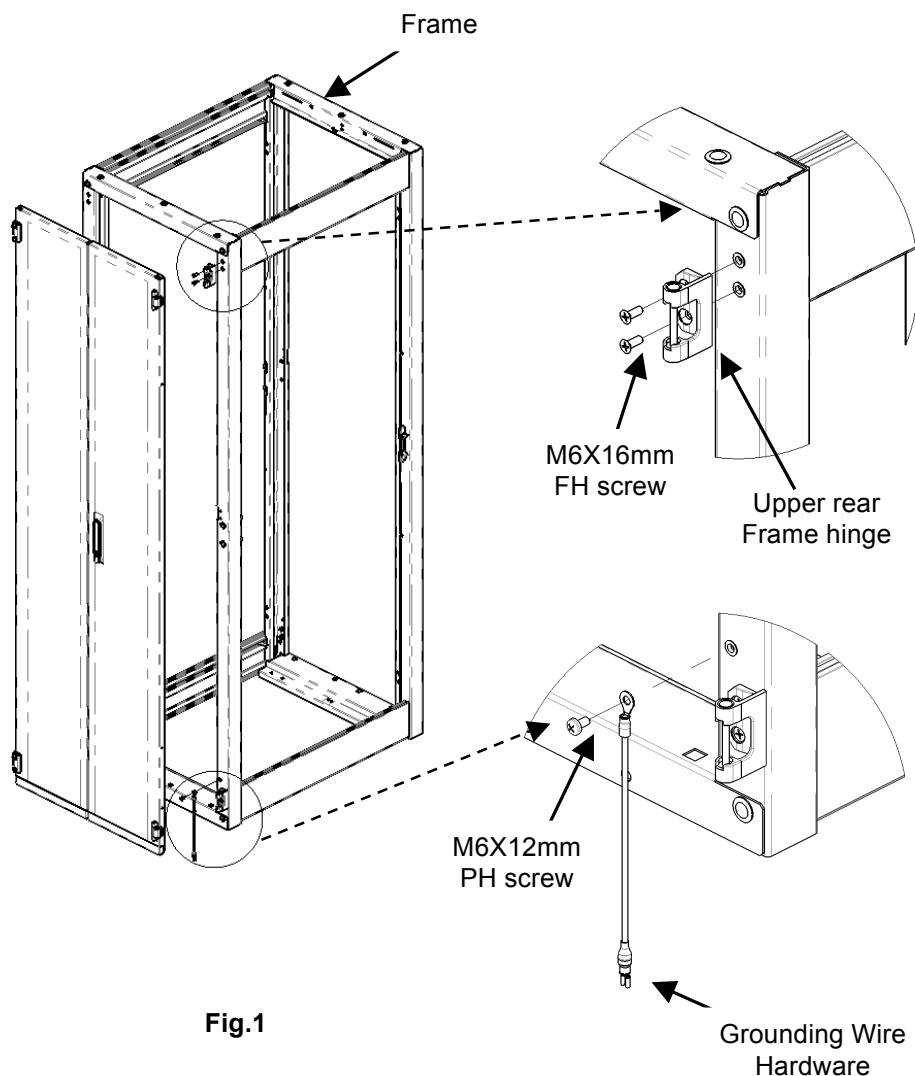

Fig.1



IIS-739050, 02/18/13, Rev. 1, CPI/JAG  
800-834-4969 (USA & Canada) • [www.chatsworth.com](http://www.chatsworth.com) • [techsupport@chatsworth.com](mailto:techsupport@chatsworth.com)  
For international phone numbers, see our website or contact CPI Tech Support.

*This drawing contains proprietary and confidential information and is protected by U.S. and international law. Unauthorized reproduction, disclosure or use of the drawing or the information therein is expressly forbidden except as agreed to in writing by Chatsworth Products, Inc.*

# Installation Instructions

## REAR DOUBLE DOOR

3. Hold one door firmly with a hand on each side. With the door held perpendicular to the cabinet, slide the door onto the hinges and rotate to close (Fig. 2).
4. Insert the hinge pins into the hinges from the top. Push the pins down into the hinges until their tops are flush with the tops of the hinges. It may be necessary to lightly tap on the tops of the pins to seat them (Fig. 2).
5. Repeat steps 1-4 for the other door.

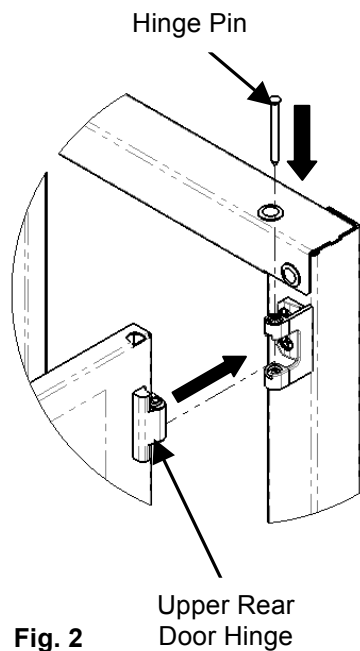

6. Electrically bond the doors to the cabinet frame by plugging the quick-connect end of the bonding jumper wire onto the quick-connect tab nearest the bottom door hinge (Fig. 3).
7. To remove the doors, unplug the quick-connect end of the bonding jumper wire from the door. With the door closed, remove the hinge pins by pushing the pins up from the bottom with a tool such as a small screwdriver. Hold the door firmly with a hand on each side. Open the door until it is perpendicular to the cabinet and slide the door out of the hinges. Repeat for the other door (Fig. 3).

