

# Installation Instructions

## RMR WALL-MOUNT REAR BACKPLANE ASSEMBLY

### Safety Information



**WARNING:** Improper use of this product may lead to serious injury. Read and understand all instructions for proper installation and use of this product.

### Tools Required

M13 Socket Driver

### Included Hardware

- (4) M8 Serrated Flange Hex Nut
- (4) Plastic Spacer

### Assembly Sequence

1. Install Plastic Spacers over M8 Studs in Cabinet
2. Install Back Plane (arrow at top) onto M8 Studs
3. Attach nuts and tighten. (torque 168 IN-LB [19.0 N-M])

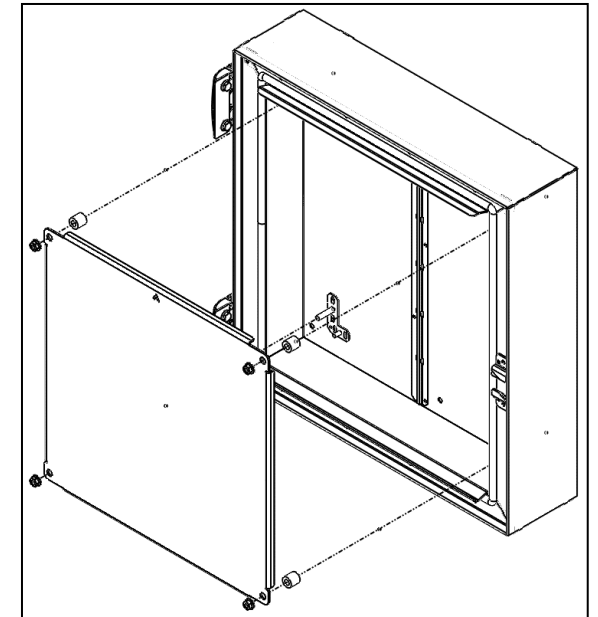
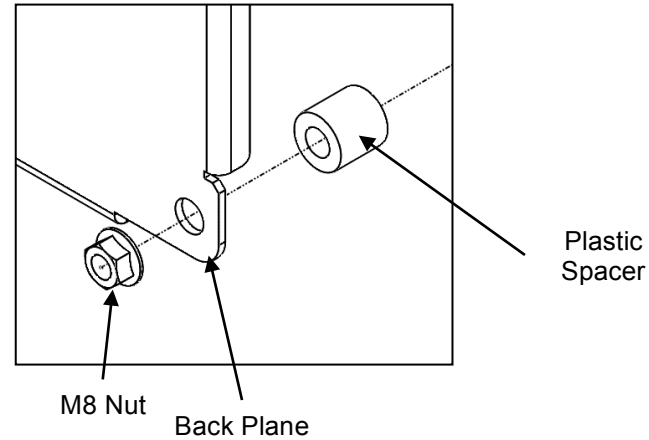

IIS-737075, 09/16/16, Rev. 1, CPI/SJG  
800-834-4969 (USA & Canada) • [www.chatsworth.com](http://www.chatsworth.com) • [techsupport@chatsworth.com](mailto:techsupport@chatsworth.com)  
For international phone numbers, see our website or contact CPI Tech Support.

*This drawing contains proprietary and confidential information and is protected by U.S. and international law. Unauthorized reproduction, disclosure or use of the drawing or the information therein is expressly forbidden except as agreed to in writing by Chatsworth Products, Inc.*