

# Installation Instructions

## RMR WALL-MOUNT CENTER BACKPLANE ASSEMBLY

### Safety Information



**WARNING:** Improper use of this product may lead to serious injury. Read and understand all instructions for proper installation and use of this product.

### Tools Required

M13 Socket Driver

### Included Hardware

- (4) M8 Serrated Flange Hex Nut
- (8) M5.5x9 Torx Panhead Screw
- (4) M6 Star Washer

### Assembly Sequence

1. Insert tab on Mounting Bracket into square hole
2. Attach with two M5.5 Torx screws with Star Washer (Torque 44 IN-LB [5 N-M]).
3. Insert Back Plane onto M8 Studs on Mounting Brackets (arrow on top)
4. Secure with M8 Nuts (Torque 168 IN-LB [19.0 N-M])

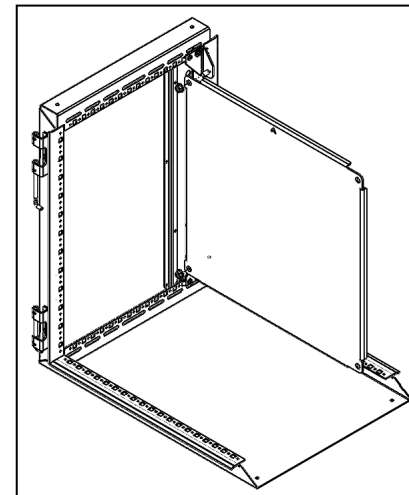
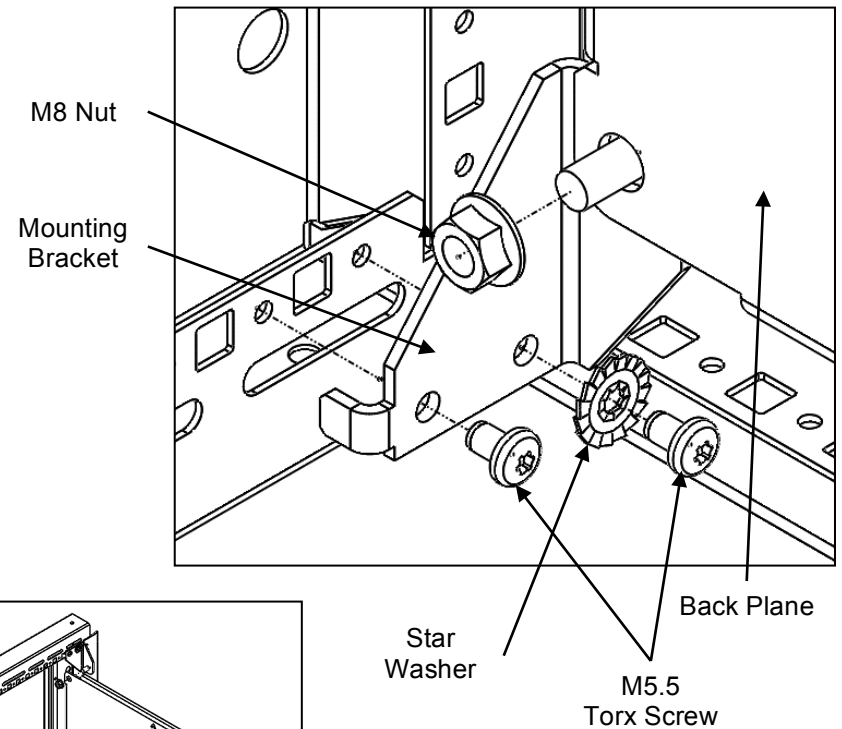

Inside Cabinet  
Top and Sides  
hidden for  
clarity



IIS-737076, 09/16/16, Rev. 1, CPI/SJG  
800-834-4969 (USA & Canada) • [www.chatsworth.com](http://www.chatsworth.com) • [techsupport@chatsworth.com](mailto:techsupport@chatsworth.com)  
For international phone numbers, see our website or contact CPI Tech Support.

*This drawing contains proprietary and confidential information and is protected by U.S. and international law. Unauthorized reproduction, disclosure or use of the drawing or the information therein is expressly forbidden except as agreed to in writing by Chatsworth Products, Inc.*