

Installation Instructions

RMR PARTIAL MOUNTING PANEL ASSEMBLY

Safety Information



WARNING: Improper use of this product may lead to serious injury. Read and understand all instructions for proper installation and use of this product.

Tools Required

10mm socket wrench
T30 Torx screw driver

Included Hardware

- (8) M6 Drop-in nut
- (8) M6X10 Serrated Flange Hex Head screw
- (4) M8 Cage nut
- (4) M8 Shoulder screw

Assembly Sequence

1. Attach mounting brackets (2 Left and 2 Right) to frame vertical members using M6 drop-in nuts and screws.

Position top brackets for desired panel height. Insert M6 drop-in nut into Double-D Cam Holes on vertical frame members and rotate 90 degrees to engage frame. Secure mounting brackets with M6 serrated flange screws (torque 168 IN-LB [19 N-M]).

Repeat process for bottom brackets and position as shown on table:

CAB HEIGHT	VACANT HOLES BETWEEN BRACKETS	
	14	3
1200H	14	3
1800H	26	8
2000H	30	10
2100H	31	12
2200H	33	12
2400H	37	14
	HALF PANEL (37840)	QUARTER PANEL (37842)

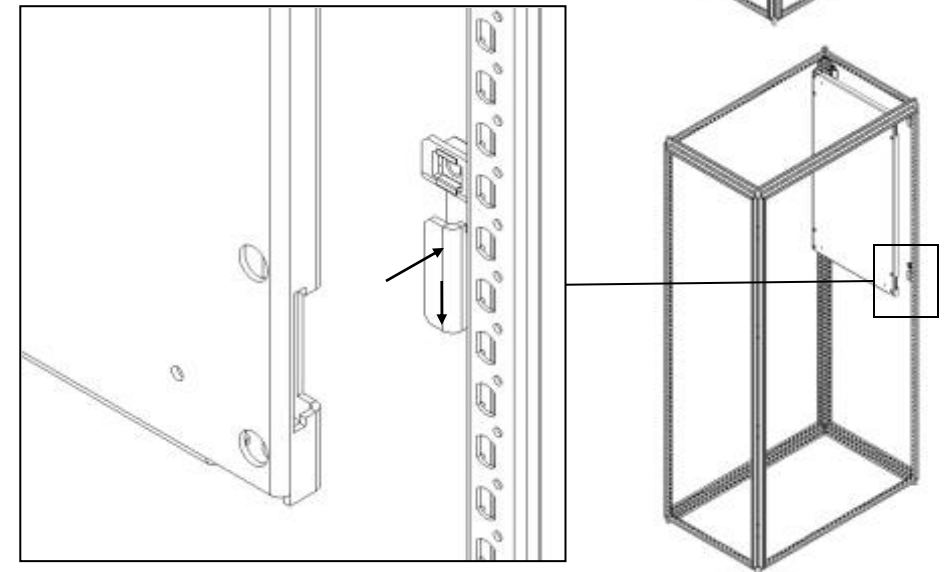
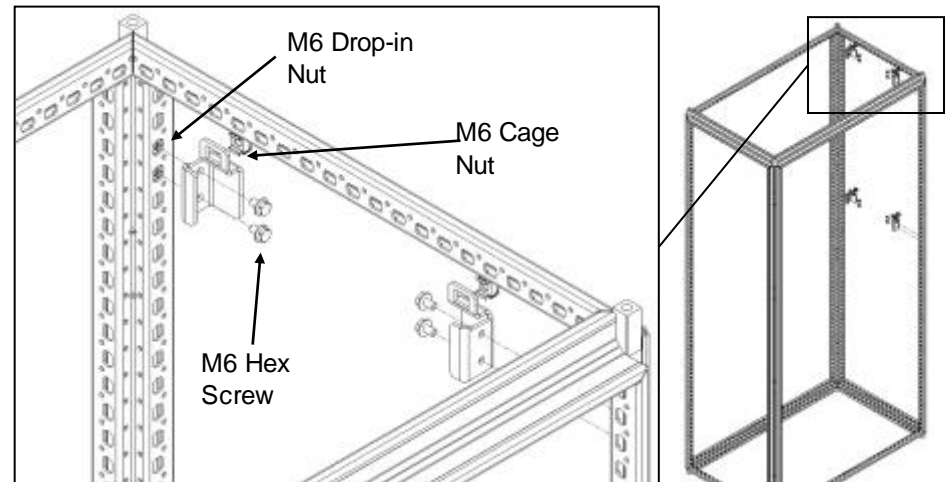

IIS-737840, 07/21/16, Rev. 1, CPI/JAG
800-834-4969 (USA & Canada) • www.chatsworth.com • techsupport@chatsworth.com
For international phone numbers, see our website or contact CPI Tech Support.

This drawing contains proprietary and confidential information and is protected by U.S. and international law. Unauthorized reproduction, disclosure or use of the drawing or the information therein is expressly forbidden except as agreed to in writing by Chatsworth Products, Inc.

Installation Instructions

RMR PARTIAL MOUNTING PANEL ASSEMBLY

2. Position mounting panel onto support brackets.
3. Secure mounting panel to support brackets using M8 shoulder screws (torque 300 IN-LBS [33.9 N-M]).

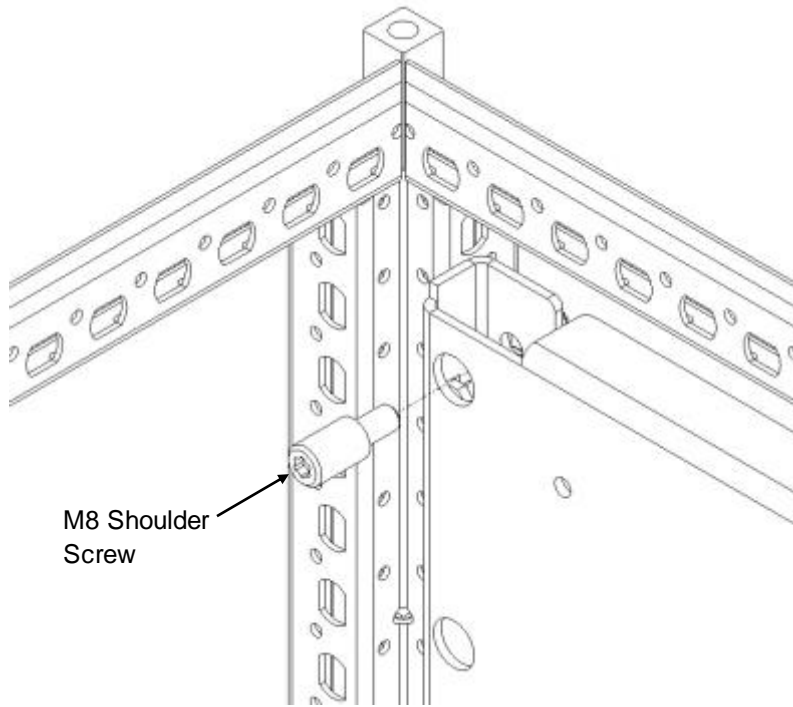

4. 600W Partial Panels can be mounted to equipment rails using the M6 serrated flange screws (torque 168 IN-LB [19 N-M]) and M6 cage nuts (supplied with equipment rails).

