

# Installation Instructions

## RMR MODULAR SOLID REAR PANEL

### Safety Information



**WARNING:** Improper use of this product may lead to serious injury. Read and understand all instructions for proper installation and use of this product.

### Tools Required

T30 Torx driver

### Included Hardware

(16) M6 X16 Fat head Torx screws

(8) Panel attach brackets with cage nuts

### Assembly Sequence

1. Attach (8) Panel mount brackets, four (4) on each side, to the frame as shown in Figure 1 with the M6X16 Torx screws provided, torque to 55in-lb[6.2N-M].



**WARNING:** Do not over torque brackets.

2. Lift rear panel to move it onto cabinet frame with the upper flange resting on top rear frame member as shown in Figure 2.
3. Secure rear panel onto frame as shown in Figure 3 with M6X16 Torx screws, torque to 55in-lb [6.2N-M].

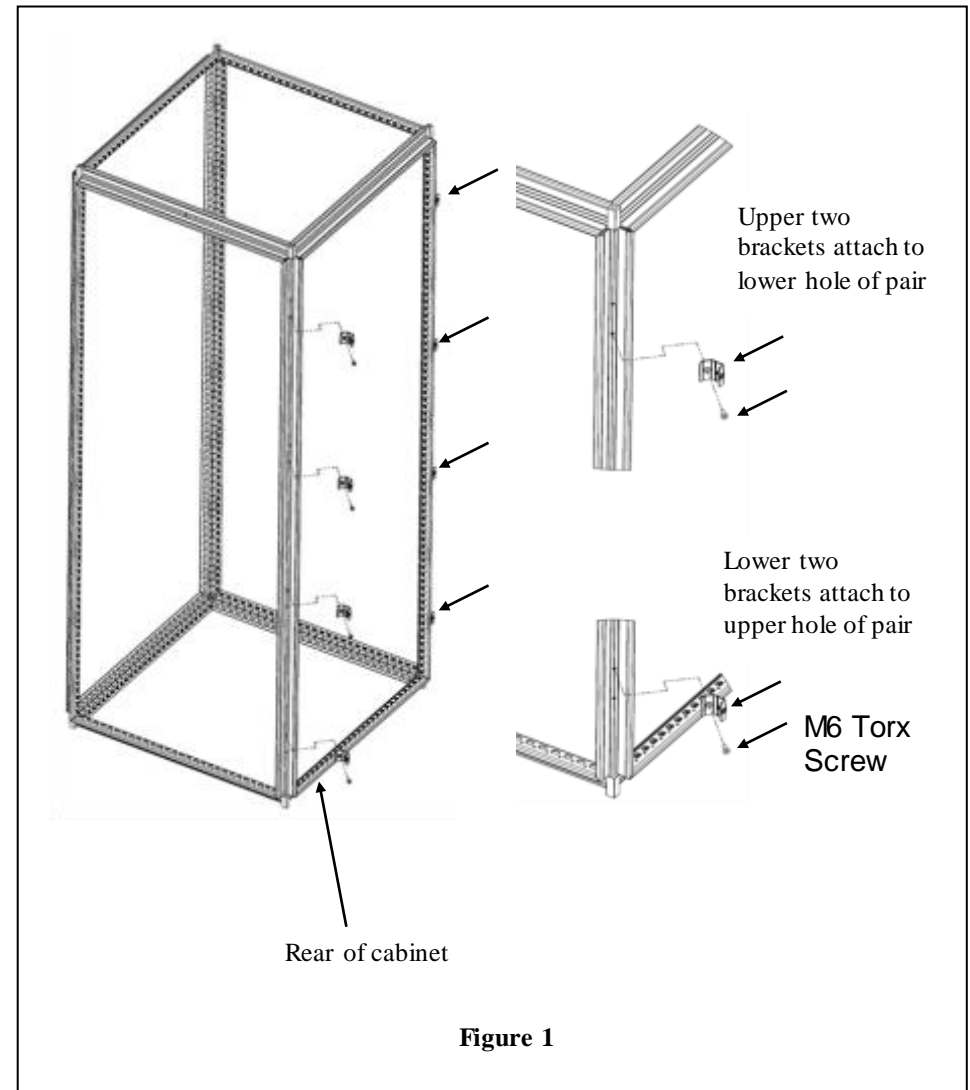

**Figure 1**



IIS-737880, 08/31/16, Rev. 1, CPI/REL

800-834-4969 (USA & Canada) • [www.chatsworth.com](http://www.chatsworth.com) • [techsupport@chatsworth.com](mailto:techsupport@chatsworth.com)

For international phone numbers, see our website or contact CPI Tech Support.

*This drawing contains proprietary and confidential information and is protected by U.S. and international law. Unauthorized reproduction, disclosure or use of the drawing or the information therein is expressly forbidden except as agreed to in writing by Chatsworth Products, Inc.*

# Installation Instructions

## RMR MODULAR SOLID REAR PANEL

