

Installation Instructions

SeismicFrame® Two-Post Rack

Safety Information



WARNING: To reduce the risk of personal injury or damage to equipment, the rack must be anchored to the concrete floor. Two or more racks can be bayed to enhance stability, but each rack must be anchored to the floor.



WARNING: Improper use of this product may lead to serious injury or death. Read and understand all instructions for proper installation and use of this product.



WARNING: Be sure to use sufficient personnel (minimum two) to safely remove the rack from the pallet.



WARNING: Do not load equipment into the rack prior to it being anchored to the floor, as it could tip over.



WARNING: For protection of the equipment and personnel, bond each rack individually to a busbar or signal reference grid.



WARNING: The rack should be installed in accordance with the NEC (National Electric Code).

Install this rack in Restricted Access Locations only. Use indoors only, in environmentally controlled areas; do not use outdoors, in harsh environments or in air-handling spaces. Use this rack for computer equipment, including servers, peripherals and telecommunication equipment. Allow only qualified service personnel to use this rack.

Load Rating

This rack has a maximum payload rating (dynamic) of 1,000 lb. (454 kg), tested and certified by independent testing laboratory to meet zone 4 GR-63 NEBS. The rating is based on a uniformly distributed load.

Tools Required

- 10 mm open end wrench (to install grounding block)
- Flat and Phillips screw driver
- 1/2" socket/driver or wrench (to install rack-to-runway mounting plate)
- Measuring tape, marker and snap line to mark hole locations
- Concrete drill and appropriately sized bit to install anchors
- Wire brush and compressed air or vacuum to clean holes
- Appropriately sized ratchet and driver to install anchors
- Additional tools to install optional accessory products.

Seismic Anchor Kit (Optional)

Anchors are NOT included. You must purchase a suitable anchor kit.

Intended Use

The SeismicFrame Two-Post Rack is an open, two-post rack designed to provide seismic protection on Data Com and TeleCom equipment. SeismicFrame Two-Post Rack provides support for 19" wide or 23" wide rack-mount network and cable management equipment that is designed to panel mount on 3" deep or 6" deep pair of equipment mounting rails.

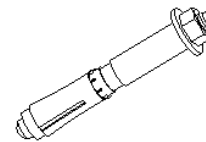

Concrete Floor Anchor Kit
(sold separately)

CPI P/N 13702-001



CHATSWORTH PRODUCTS

IIS-713853, 03/22/2017, Rev.6, D Robertson

800-834-4969 (USA & Canada) • www.chatsworth.com • techsupport@chatsworth.com

For international phone numbers, see our website or contact CPI Tech Support.

This drawing contains proprietary and confidential information and is protected by U.S. and international law. Unauthorized reproduction, disclosure or use of the drawing or the information therein is expressly forbidden except as agreed to in writing by Chatsworth Products or the information therein is expressly forbidden except as agreed to in writing by Chatsworth Products.

Installation Instructions

SeismicFrame® Two-Post Rack

Install this rack only in a restricted service environment, such as a data center.

Included Hardware

2 each
6mm Lock Nut



4 each
Anchor Washer

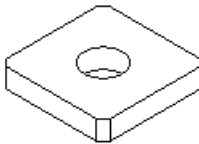

1 each
Grounding Block

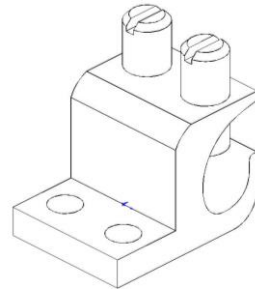

2 each
5/16 X7/8 Bolt, Lock Washer, Hex Nut

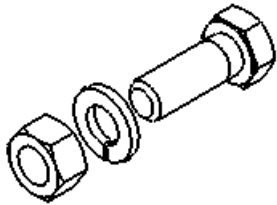

1 tube Antioxidant Compound

50 each 12-24 x 5/8 Screws, for tapped rail version **OR**
50 each 12-24 Cage Nuts & Screws, for square punched rail version

Installation Notes:

- A licensed structural engineer familiar with seismic applications and code in the area where the rack will be installed should be consulted for exact location and anchorage of the rack.
- Each Seismic Frame Two-Post Rack must be secured to the structural floor with four seismic-rated concrete slab floor anchors. CPI recommends M12 x 5-1/2" L Hilti HSL-3-G Heavy Duty Sleeve Anchors (CPI P/N 13702-001).
- A floor drilling template (CPI P/N 13703-701) is available as an installation aide to help locate floor mounting hole centers for single and multiple rack installation.
- When bayed in a continuous row, the spacing between racks should be determined by a licensed structural engineer. Each installation requirement varies depending on various factors such as site class, building construction, and many other conditions. One common installation is to space 6-1/2" (165 mm) apart when anchored to the concrete slab on grade or 10-1/2" (267 mm) apart when anchored to concrete over steel decking above grade with recommended hardware to allow proper spacing between anchors. Use vertical cable managers to fill the space between racks and store cables.
- Equipment mounting rails can be set 6" (150 mm) or 3" (80 mm) apart. Racks deliver fully assembled with rails set 6" (150 mm) apart. 6" (150 mm) rail spacing is preferred. If repositioned, attach the center bolt first.
- Secure equipment to the rack using all mounting holes. If equipment is placed on a shelf, brace equipment to the rack using an auxiliary bracket so that equipment is held on the shelf and to the rack. Do not leave loose hardware on the rack or on shelves. Loose hardware can be thrown from the rack/shelf during a seismic event.
- Always load heavier equipment, such as a UPS, at the bottom of the rack. Extend only one server at a time. Unload equipment from the rack before moving it.
- Cable Runway may be attached directly to the top of the rack with J-bolts or a Rack-To-Runway Mounting Plate. Do not drill the top of the rack to attach cable runway. Secure the rack to the floor before installing runway and locate the runway from the pre-drilled attachment points on the top of the rack. Use included 2 each of 5/16" x 7/8" bolt/washer/nut to attach a Rack-To-Runway Mounting Plate.

Installation Instructions

SeismicFrame® Two-Post Rack

Assembly Sequence

1. Review installation instructions for the seismic-rated anchors that will be used to secure the rack to the floor. Note any special requirements and request review by project engineer, if required. If mounting other than on a 6 inch thick concrete floor, please consult with a licensed structural engineer.
2. Mark the location of the front and side of the rack/racks from the floor plan. The rack must be attached directly to the structural concrete floor. Anchoring to raised floor tiles-only is not recommended unless previously approved by a structural engineer.
3. Use the rack or floor template (CPI P/N 13703-001) to locate four mounting holes. The mounting holes at the base of the rack are obround with size 1.23" X 2.75" (32mm X 70mm). The black dots are representing 18 mm diameter anchor drill bit.
4. Check the location of the rack against the floor plan.
5. Move the rack and drill appropriately sized holes to attach the rack to the floor. The size and depth of the hole must match anchor requirements as advised by the anchor manufacturer/project engineer.
6. Remove dust and debris from the holes in the floor.
7. Position and align the rack over the holes in the floor.
8. Anchor the rack to the floor using seismic-rated anchors and four provided anchor washers. Secure anchors using instructions provided by the anchor manufacturer.

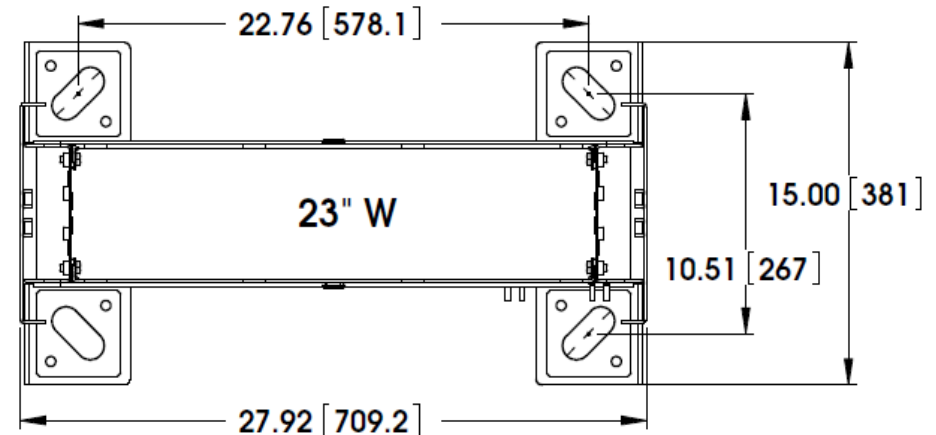
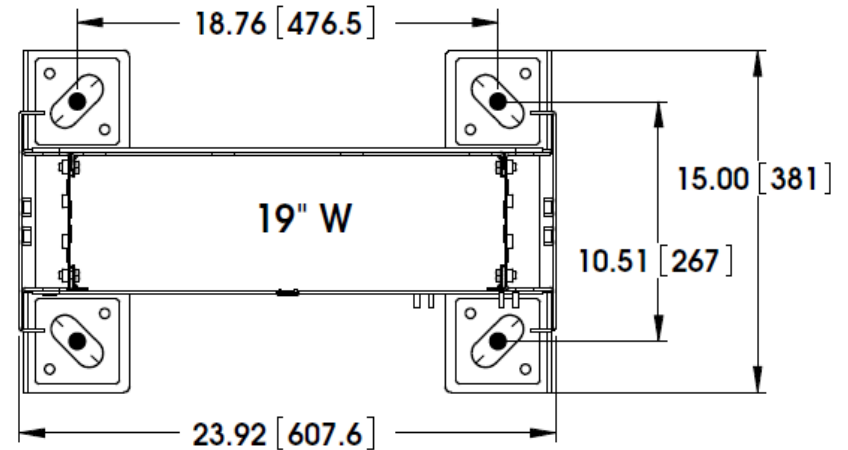

Installation Instructions

SeismicFrame® Two-Post Rack

Optional Cable Management Fingers snap in place along front/rear edge of rack

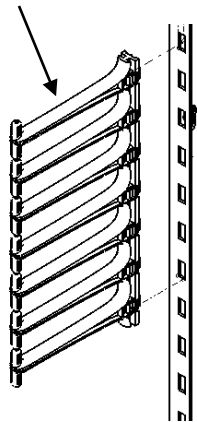

Eye bolt attachment hole
(Diameter: .750" / 19 mm)
(Eye bolts are not included)

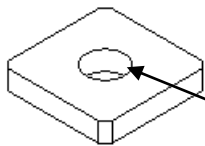
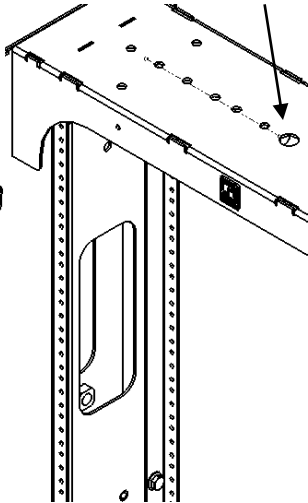

Anchor Washer
(Diameter: .750" / 19 mm)

Remove tape to expose bare metal and apply antioxidant to the bare metal before attaching grounding block

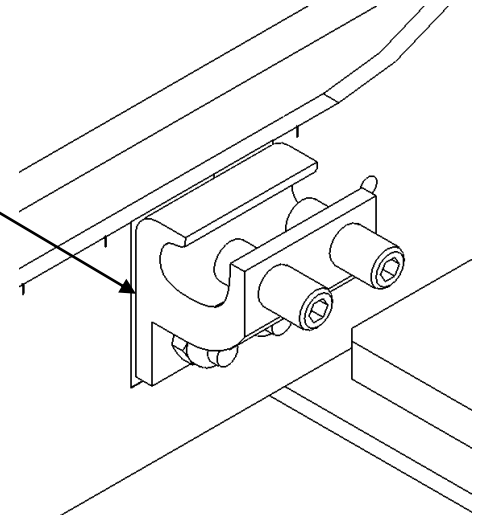

Shows some examples of Rack-to-Runway Mounting Plate

