

Raised Floor Grommets

CPI's Raised Floor Grommets provide a reliable seal around cable bundles. The rectangular grommet features a dual-layer brush with an integrated EPDM membrane for a superior seal. The Round grommet option offers a cabling solution in limited spaces.



ADVANTAGES

- ➔ Split design allows for retrofitting over existing cable bundles in access floor tiles.
- ➔ Economical and effective solution promotes efficient airflow management.
- ➔ Nylon filament brushes provide robust sealing capacity around cables.
- ➔ Rectangular Raised Floor Grommet includes dual-layer brush with an integrated EPDM membrane that provides a superior seal around cable bundles.
- ➔ Grommet materials resist breaking, deformation and wear for repeated use.

KEY FEATURES

- Split design allows easy addition around existing cables. Add cable openings to the edge of floor tiles for easy addition or removal of cables
- Rectangular Raised Floor Grommet features EPDM membrane between two layers of nylon brushes that forms a superior seal around cable bundles
- 4" Round Raised Floor Grommet offers smaller form-factor where space is limited
- Durable sealing materials will not break, tear or deform from repeated use
- Available as singles or in carton of 10

RELATED ACCESSORIES

- Snap-In Filler Panels
- Seal Kit for Cabinets

SPECIFICATIONS

Application	Designed to seal cable bundles passing through cutouts in data center raised floor environments.
Use	For indoor use only, in environmentally controlled areas. May not be used outdoors or in harsh environments.
Rectangular Raised Floor Grommet:	Two-piece grommet frame is UL94 V-0 ABS Dual-layer brush filaments are nylon Membrane is EPDM (synthetic elastomer)
Material & Dimensions	Above floor: 10.75" x 8.25" (273 mm x 210 mm) Recommended floor opening: 9.25" x 6.75" (235mm x 171mm) cutout
4" Round Raised Floor Grommet:	Two-piece grommet frame is UL94 V-0 ABS Brush filaments are nylon
Material & Dimensions	Above Floor: 5.5" (140 mm) Recommended floor opening, requires 4" (102 mm) diameter cutout
Cable Capacity	Use CPI's Cable Fill Table to determine your product cabling needs: http://www.chatsworth.com/cablefill

SUPERIOR AIRFLOW MANAGEMENT

Chatsworth Products (CPI) Raised Floor Grommet is designed to seal new or existing cable penetrations in data center raised floor environments. The split two-piece design allows for installation along the edge of a raised floor tile. This approach does not "capture" cables and allows for quick tile removal without disrupting your network.

Durable nylon brushes provide a seal around cables to reduce bypass airflow. The rectangular grommet includes a dual-layer of brush and integrated EPDM flexible membrane that provides a superior level of sealing effectiveness.

Global Availability

US & Canada

+1-800-834-4969
Toronto, Ontario, Canada
+905-850-7770
chatsworth.com
techsupport@chatsworth.com

Latin America

+52-55-5203-7525
Toll Free within Mexico
01-800-01-7592
chatsworth.com.co

Europe

+44-1628-524-834
chatsworth.com

Middle East & Africa

Dubai, UAE
+971-4-2602125
chatsworth.ae

Asia Pacific

+86 21 6880-0266
chatsworth.com.cn



ORDERING INFORMATION



Raised Floor Grommet

- Split design does not capture or disrupt existing cables and is ideal for new and retrofit applications
- Available as singles or in carton of 10
- Convenient floor tile cut template included with installation instructions
- Includes (4) self-drilling #8 pan-head screws

Part Number	Description	Shipping Weight lb (kg)
13671-001	Raised Floor Grommet, Each	2 (1.4)
13671-002	Raised Floor Grommet, Pack of 10	18 (8.2)



4" Round Raised Floor Grommet

- Small form-factor is ideal in limited floor space
- Split design does not capture or disrupt existing cables and is ideal for new and retrofit applications
- Available as singles or in carton of 10
- Includes (4) self-drilling #8 pan-head screws

Part Number	Description	Shipping Weight lb (kg)
13874-001	4" (102 mm) Round Raised Floor Grommet, Each	1 (0.5)
13874-002	4" (102 mm) Round Grommet, Pack of 10	6 (2.7)

PRODUCT DIMENSIONS

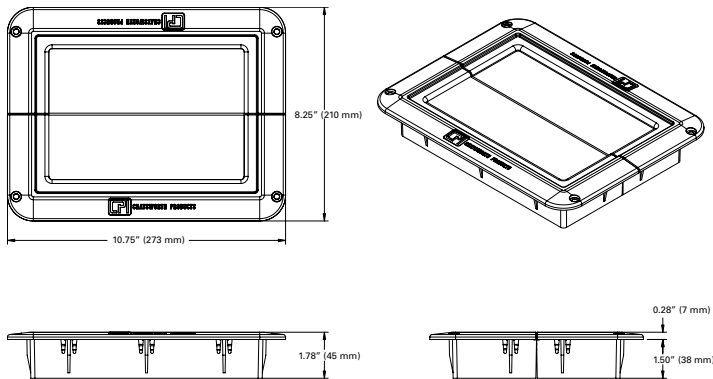

PRODUCT DIMENSIONS

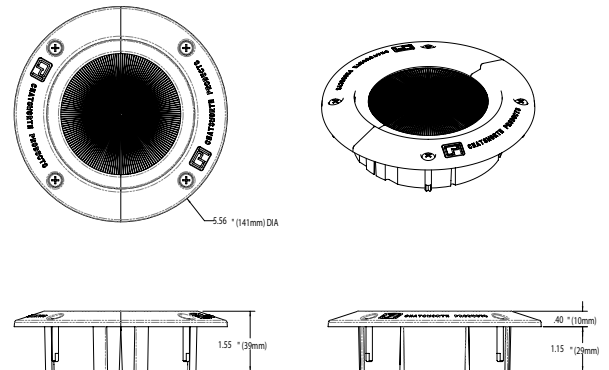

Interested in learning more about our Thermal Management? Call us at 800-834-4969, or email Technical Support at techsupport@chatsworth.com.



CPI now offers Extended Limited Warranties on CPI-Branded Electronic products, available for two additional years beyond the expiration of the Original Warranty Period (3 years).

Contact CPI Customer Service, or visit www.chatsworth.com/warranty for more information.



While every effort has been made to ensure the accuracy of all information, CPI does not accept liability for any errors or omissions and reserves the right to change information and descriptions of listed services and products.
 ©2018 Chatsworth Products, Inc. All rights reserved. Chatsworth Products, Click-Nut, CPI, CPI Passive Cooling, eConnect, Evolution, GlobalFrame, MegaFrame, Motive, OnTrac, QuadraRack, RMR, Saf-T-Grip, Secure Array, SeismicFrame, SlimFrame, TeraFrame and Velocity are federally registered trademarks of Chatsworth Products. CUBE-IT, EuroFrame and Simply Efficient are trademarks of Chatsworth Products. All other trademarks belong to their respective companies. Rev.2/08/18 MKI-60020-684