

STANDARD RACK

KEY FEATURES

- Supports 19" EIA rack-mount equipment designed for two-post panel mounting like patch panels and network switches.
- Easy positioning of equipment with marked and numbered rack-mount spaces.
- Quick attachment of equipment with threaded equipment mounting holes and included equipment-mounting screws.
- Delivers unassembled in a single carton — quick and easy bolt-together assembly takes less than 10 minutes.
- Lightweight aluminum construction for easy transport and positioning during installation.
- Quickly attach any CPI vertical cable manager to the side of the rack through pre-punched web channel holes.
- Floor-mount holes on the base angles make it easy to secure the rack to the floor with a concrete, wood or raised floor installation kit.

APPLICATIONS

- Use Standard Rack with vertical and horizontal cable managers to support interconnect and network equipment in telecommunications rooms, equipment rooms and data centers.
- Use with shelves to support other equipment.

USE WITH

- MCS Master Cabling Section
- CCS Combination Cabling Section
- Universal Horizontal Cable Manager
- Rack and Frame Installation Kit
- Raised Floor Rack Support For 3" (80 mm) Channel

RELATED ACCESSORIES

- 3" (80 mm) Channel Rack-To-Runway Mounting Plate
- Vertical PDUs for Racks
- Rack Shelves

Increased Load Rating

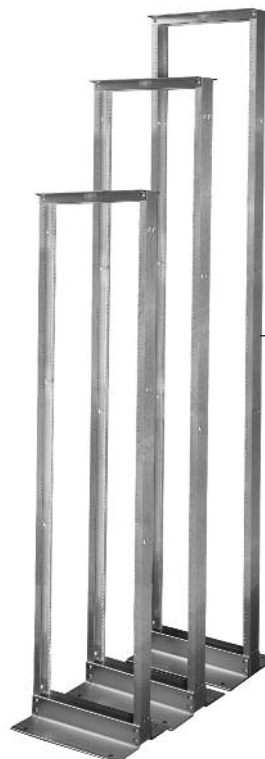

RMU marks simplify equipment installation

The Standard Rack is a high quality, cost-effective storage solution for patch panels and network switches that uses less floor space than a cabinet or a four-post rack. The small 20.3"W x 15"D (516.1 mm x 381 mm) footprint makes Standard Rack the best choice in many telecommunications and equipment rooms, especially where floor space is limited.

The Standard Rack meets project specifications, will hold 1,000 lb (453.1 kg) of equipment and is UL Listed as a communications circuit accessory. Support 19" EIA wide rack-mount equipment or shelves with the Standard Rack which is available in three heights. Equipment attaches to the front or rear of the 3" deep (80 mm) vertical mounting channels with screws. Mounting positions are marked and numbered making it easy to position and install equipment or shelves.

Racks deliver unassembled in a compact carton, and are easy to assemble. Components bolt together with included hardware; assembly takes approximately 10 minutes. Two-post racks must be secured to building structure. The Standard Rack has pre-punched base angles making it easy to attach the rack to the floor using a CPI installation kit for wood, slab or raised floors.

Because most Standard Rack applications require cable management, CPI's vertical cable managers attach directly to the side of the Standard Rack. Vertical cable managers organize cables by rack-mount space simplifying future moves, adds and changes to the network. The best solution includes horizontal managers in between patch panels and network switches to fan patch cords into individual port connections.

See reverse for product selection. Contact CPI Technical Support for configuration assistance.

SPECIFICATIONS

- Open floor-mount two-post rack supports 19" EIA wide rack-mount equipment
- For indoor use only, in environmentally controlled areas; may not be used outdoors, in industrial or harsh environments, or in plenum spaces
- Available sizes:
 Heights: 84" (2.1 m), 96"(2.4 m), 108", (2.7 m)
 Width: 20.3" (516.1 mm)
 Depth: 15" (381 mm)
- Equipment space:
 Heights: 45 RMU, 51 RMU, 58 RMU
 Width: 19" EIA (17-3/4" clearance)
 Depth: 20"D (508 mm)
Note: Double-sided shelves for 26"D (660.4 mm) equipment are available. Use QuadraRack™ 4-Post Frame when rack-mount equipment exceeds 20"D. (508 mm)
- Equipment Support:
 1 pair C-shaped equipment mounting channels fixed in place
 - 19"W, EIA-310-D compliant
 - Universal hole pattern, 5/8"-5/8"-1/2" (15.9 mm x 15.9 mm x 12.7 mm) vertical hole spacing
 - Threaded #12-24 equipment mounting holes
 Includes 50 each #12-24 equipment mounting screws
- Cable Management
 Use vertical and horizontal cable managers, sold as accessories
- Load capacity:
 1,000 lb (453.6 kg) of equipment
- Certifications:
 EIA-310-D compliant
 UL Listed as a communications circuit accessory
- Material:
 Aluminum extrusion
- Construction:
 Bolted assembly
 Ships unassembled
- Finish:
 Clear grained aluminum or
 Epoxy-polyester hybrid powder coat paint
 Available in black, gray or computer white

DIMENSIONS

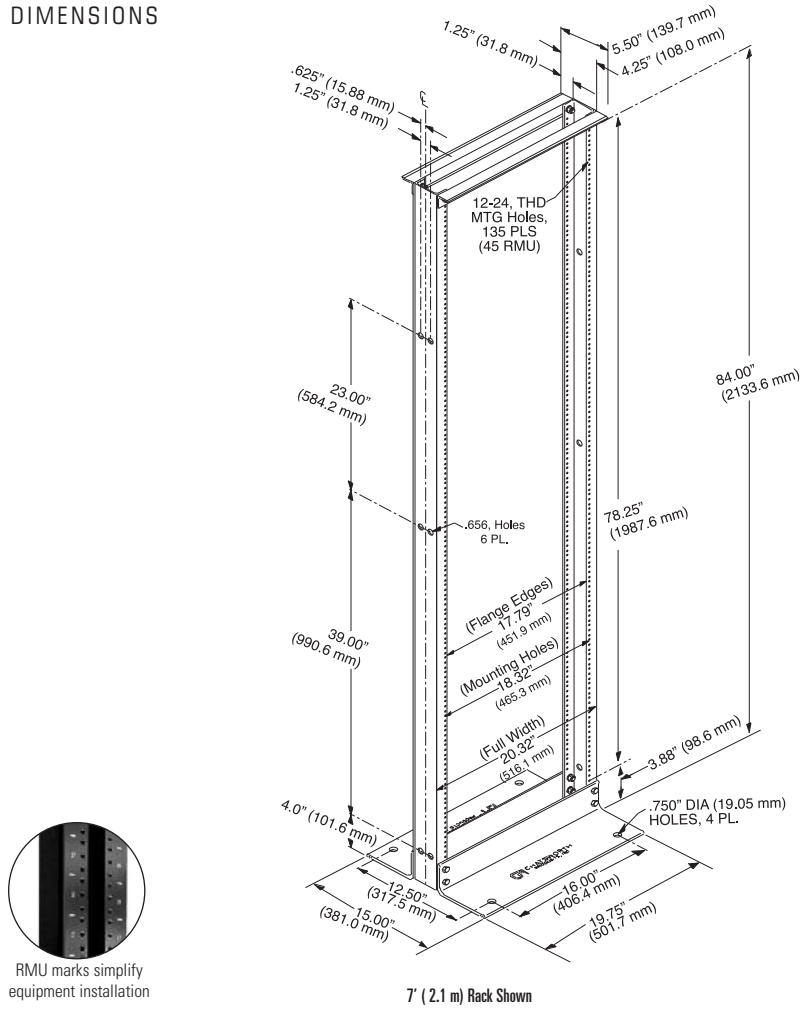

ORDERING INFORMATION

Part Number	Description	Shipping Weight
55053-X03	19"W X 7'H (2.1 m), 45 RMU	31 lb (14.1 kg)
55053-X15	19"W X 8'H (2.4 m), 51 RMU	37 lb (16.8 kg)
55053-X08	19"W X 9'H (2.7 m), 58 RMU	40 lb (18.1 kg)

X=color: 1=Gray, 2=Computer White, 5=Clear, 7=Black

