

Frequently Asked Questions

Adjustable Rail QuadraRack™ and ServerRack

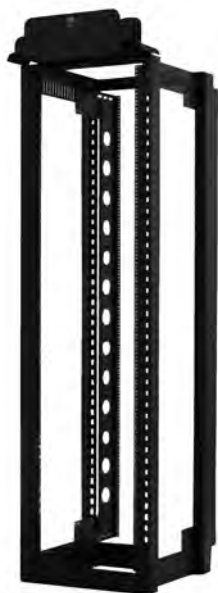

Q. What is the difference between the Adjustable Rail QuadraRack™ (ARQR)/ServerRack (ARSR) and Adjustable QuadraRack™ (AQR)/ServerRack (ASR)?

A. Both systems offer front and rear support for equipment; however, only the Adjustable Rail QuadraRack™ /ServerRack can adjust in depth after the frame is assembled and installed. The original Adjustable QuadraRack™/ServerRack is adjusted in depth before installation and is fixed in depth after it is assembled and installed.

- AQR/ASR = adjustable depth upon installation, fixed rails after installation
- ARQR/ARSR = fixed depth, adjustable rear rails after installation

What is the difference between the Adjustable Rail QuadraRack and Adjustable Rail ServerRack?

A. The only difference between the Adjustable Rail QuadraRack and the Adjustable Rail ServerRack is the style of the equipment mounting rails. The Adjustable Rail QuadraRack has equipment mounting rails with #12-24 threaded mounting holes. Equipment is attached with #12-24 screws. The Adjustable Rail ServerRack has equipment mounting rails with square-punched mounting holes that accept cage nut hardware with various threads. Cage nuts snap into the holes allowing the threads at each RMU space to be changed to match equipment requirements.

Q. When should I use the Adjustable Rail QuadraRack?

A. Use the Adjustable Rail QuadraRack with #12-24 threaded equipment mounting holes in network facilities to support patch panels, fiber enclosures and network switches. This type of equipment typically attaches to the rack at the front only with a mounting bracket. Threaded mounting holes speed equipment installation because a cage nut does not have to be added at each attachment point.

Q. When should I use the Adjustable Rail ServerRack?

A. Use the Adjustable Rail ServerRack with square-punched equipment mounting holes in data centers and computer rooms to support rack-mount server and data storage equipment. Square punched mounting holes let you change mounting hardware at each RMU space to match equipment requirements. Rack-mount server and data storage equipment usually includes mounting rails and each type of equipment may require a different type of installation hardware.

Q. Which rack should I use if I am using a mix of computer and network equipment or don't know what type of equipment I will place in the rack?

A. If you are not certain what type of equipment will be placed in the rack, use the Adjustable Rail ServerRack with square-punched equipment mounting holes. This rack will support all types of equipment.

Q. What is "adjustable" about the rack?

A. The rack is a fixed depth four-post frame, but the rear mounting rail of the rack can be adjusted in depth allowing the front-to-rear mounting depth of the rack to be changed after the rack is assembled and installed. The rear mounting rail is infinitely adjustable between 15" (380 mm) and the maximum rail depth with rack attachment points at .98" (25 mm) increments.



CHATSWORTH PRODUCTS, INC.

800-834-4969

techsupport@chatsworth.com
www.chatsworth.com

Frequently Asked Questions

Adjustable Rail QuadraRack™ and ServerRack

Q. Which “depth” rack should I use to support my equipment?

A. The Adjustable Rail QuadraRack and the Adjustable Rail ServerRack are available in two depths: 23.62” (600 mm) and 35.43” (900 mm). The 23.62” deep (600 mm) rack will fit within a single access floor tile. The depth of the rear mounting rails can be adjusted on both racks. The mounting rails on the 23.62” deep (600 mm) rack can be adjusted between 15” deep (380 mm) and 29.52” deep (750 mm). The mounting rails on the 35.43” deep (900 mm) rack can be adjusted between 15” deep (380 mm) and 41.33” deep (1050 mm). Check equipment specifications for the exact mounting depth requirements of equipment and adjust the depth of the rear mounting rails accordingly.

Q. Is rack-mount installation hardware included with the rack?

A. Yes, each Adjustable Rail QuadraRack includes (50) #12-24 mounting screws and each Adjustable Rail ServerRack includes (50) #12-24 cage nuts with screws. . You can order additional #12-24 cage nuts with screws (P/N 12639-001), #10-32 cage nuts with screws (P/N 12638-001), M6 cage nuts with screws (P/N 12637-001) or #12-24 mounting screws (P/N 40605-001 for zinc, P/N 40605-005 for black) separately. Note that cage nuts are sold in packs of 25.

Q. Are the RMU spaces marked and numbered on the equipment mounting rails?

A. Yes, the RMU spaces are marked and numbered on both sides of the front pair of equipment mounting rails.



Q. The equipment mounting brackets included with my rack-mount equipment are not deep enough to span front-to-rear between the rack-mounting channels. How do I attach or place equipment in the rack?

A. Use a 4-Post Shelf (P/N 15245-XXX or P/N 15255-XXX) or Equipment Support Rail (P/N 15285-XXX) to help support equipment. 4-Post Shelves use 1 RMU and hold 200 lb (90.7 kg) of equipment. The shelves have adjustable mounting brackets that adjust front-to-rear in depth to match the rear mounting rails of the rack. Equipment Support Rails attach to the sides of the rack, use no RMU spaces and help support up to 200 lb (90.7 kg) of equipment. Equipment Support Rails are L-shaped supports along the side of the rack and help support rack-mount equipment. The front of the equipment is attached to the rack-mount rail at the front of the rack.

Q. Can I use the QuadraRack™ 4-Post Frame and QuadraRack™ ServerFrame shelves and accessories on the Adjustable Rail QuadraRack and Adjustable Rail ServerRack?

A. The Adjustable Rail QuadraRack and Adjustable Rail ServerRack will support the QuadraRack™ 4-Post Frame and Server Frame shelves when the mounting rails are set to 29” deep (740 mm). These shelves are not recommended on the 23.62” deep (600 mm) rack.

Q. Can the Adjustable Rail ServerRack and Adjustable Rail QuadraRack be assembled into multi-rack bays?

A. Yes, the Adjustable Rail QuadraRack and Adjustable Rail ServerRack have the same side hole pattern as the Standard Rack, Universal Rack, 6” Deep Standard Rack, QuadraRack 4-Post Frame, QuadraRack Server Frame, Adjustable QuadraRack and Adjustable ServerRack and can be bayed together with these racks to create a multi-rack bay. Use the Rack Line-Up Spacer Kit (P/N 40702-X00 or P/N 40602-X00) to connect the racks together side-by-side.

Q. Can CPI vertical cable managers be used with the Adjustable Rail QuadraRack and Adjustable Rail ServerRack?

A. Yes, the Adjustable Rail QuadraRack and Adjustable Rail ServerRack have the same side hole pattern as Standard Rack, Universal Rack, 6” Deep Standard Rack, QuadraRack

Frequently Asked Questions

Adjustable Rail QuadraRack™ and ServerRack

4-Post Frame, QuadraRack ServerFrame, Adjustable QuadraRack and Adjustable ServerRack and can be used with all CPI vertical cabling sections including VCS Vertical Cabling Sections, MCS Master Cabling Sections, CCS Combination Cabling Sections and Global Vertical Cabling Sections. The cabling section and rack must be the same height. Cabling sections can be used in between racks in a multi-rack bay to create vertical cable pathways between racks. Side panels are also available to cover the end of a bay of racks.

Q. Can I use a side panel on the end of a multi-rack bay if a CPI vertical cable manager is at the end of the bay?

A. Yes, the side panel is sized to match the rack and can attach to the side of the rack or CPI cabling section. If there is only one cabling section, a standoff bracket that is included with the side panel supports the end of the side panel opposite the Cabling Section from the rack.

Q. How does the side panel attach to the rack?

A. The side panel hangs on four angled brackets that attach to the side of the rack through the holes typically used for cabling sections (vertical cable managers). The side panel is secured with two threaded knobs that catch under the top set of angled brackets. Note that the side panels are sized to match the Adjustable Rail QuadraRack and Adjustable Rail ServerRack and are not compatible with other racks, but can be attached

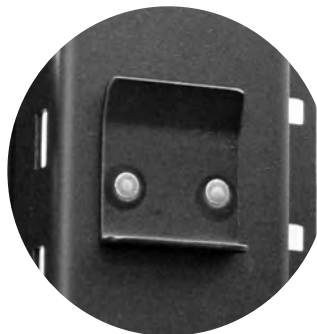

Bracket secures side panel to rack



to cabling sections that are attached to the racks.

Q. Can CPI horizontal cable managers be used with the Adjustable Rail QuadraRack and Adjustable Rail ServerRack?

A. Yes, the Adjustable Rail QuadraRack and Adjustable Rail ServerRack support 19" wide EIA equipment. All CPI 19" wide horizontal cable managers including Universal Horizontal Cable Manager, 19" Horizontal Wire Management Panel, Large Horizontal Ring Panel, Rack Cabling Managers and Jumper and Transition Trays will attach to Adjustable Rail QuadraRack and Adjustable Rail ServerRack. CPI recommends planning a minimum of 1 RMU of horizontal cable management space for every 2 RMU of connectivity. For Cat 6A UTP cable, plan 1 RMU of horizontal cable management space for every 1 RMU of connectivity.

Q. Are any cable management accessories included with the Adjustable Rail QuadraRack and Adjustable Rail ServerRack?

A. Yes, the Adjustable Rail QuadraRack and Adjustable Rail ServerRack include a Top-Mount Cable Waterfall Tray that attaches to the top of the frame and creates a side-to-side pathway for patch cords. The rack also includes one 7 RMU cable guide – a T-shaped plastic cable guide that can snap onto the front or rear of the rack along both sides of the equipment mounting rails. The cable guides have openings that align with each RMU space on the rack. Additional cable guides are sold as accessories. Alternately, any CPI cabling section (vertical cable manager) can be attached to the side of the rack to create a wider and deeper space for storing cables. The MCS Master Cabling Section, CCS Combination Cabling Section and Global Vertical Cabling Section include T-shaped cable guides that align with each RMU space on the rack. Use cabling sections to manage large amounts of cable.

Q. How many 7 RMU cable guides are included with each Cable Guide Kit?

A. Each Cable Guide Kit includes enough cable guides to match the full height on one side of the rack. Use one kit for two corners (one side of the rack) – a maximum of two kits per rack. The kits are sized to match the height of the racks and include several 7 RMU cable guides and a partial cable guide to match the overall rack height.



Frequently Asked Questions

Adjustable Rail QuadraRack™ and ServerRack

Q. Can CPI Cable Runway (ladder rack) be attached directly to the top of the Adjustable Rail QuadraRack and Adjustable Rail ServerRack?

A. Yes, CPI Cable Runway that is 6" wide (150 mm) to 20" wide (510 mm) can attach directly to the top of the Adjustable Rail ServerRack and Adjustable Rail QuadraRack with a J-bolt Kit (P/N 11308-X01) or a Cable Runway Elevation Kit (P/N 10506-X02 or 10506-X06) in the perpendicular (front-to-rear) or parallel (side-to-side) orientation. As an alternative, the Cable Runway Mounting Bracket (P/N 15205-X01) can be used to attach all sizes of Cable Runway up to 24" wide (610 mm) to the top of the racks in either the perpendicular (front-to-back) or parallel (side-to-side) orientation. Cable Runway cannot attach to the front of the rack in the perpendicular (front-to-back) orientation when the top-mount cable waterfall is installed.

Q. Do CPI Vertical Power Strips attach directly to the side of the Adjustable Rail QuadraRack and Adjustable Rail ServerRack?

A. Yes, CPI Vertical Power Strips for cabinets attach to the rear rack frame or rear mounting rail using the included Versa-Clamp installation hardware.

Q. Can you attach two power strips side by side on the Adjustable Rail QuadraRack and Adjustable Rail ServerRack?

A. Yes, to install two power strips side-by-side, use the F-Series TeraFrame™ Cabinet System Dual Vertical Power Strip Manager (P/N 34595-C02 for 45 RMU racks or P/N 34595-C08 for 51 RMU racks). The Dual Vertical Power Strip Manager attaches to the rear mounting rail. (as shown below)



Q. Are the Adjustable Rail QuadraRack and Adjustable Rail ServerRack delivered assembled or unassembled?

A. The Adjustable Rail QuadraRack and Adjustable Rail ServerRack are delivered unassembled.

Q. How long does it take to assemble an Adjustable Rail QuadraRack or an Adjustable Rail ServerRack?

A. It takes one person approximately 20 minutes to assemble each rack. The Adjustable Rail QuadraRack and Adjustable Rail ServerRack are delivered unassembled in a single carton. The rectangular front and rear frames are welded. There are four side brackets that attach at the corners of the frames and a pair of rear mounting rails that attach to the rear frame. (The front mounting rails are attached to the front mounting frame aligned with the front of the frame with RMU marks beginning at the bottom of the frame, but can be reversed to align with the rear of the frame and/or mounted to allow RMU marks to start at the top of the rack.) Carriage bolts are used to assemble the rack so a single wrench/ratchet (sizes 13 mm & 10 mm) is all that is required.

Q. When should I reverse (recess) the front mounting rails on an Adjustable Rail QuadraRack or an Adjustable Rail ServerRack?

A. The front mounting rails can align with the front or rear of the rack frame. Reverse (recess) the rails to align with the rear of the rack frame when supporting equipment that draws air side-to-side so that airflow through equipment is not blocked by the side of the rack frame. The rack frame is 2.95" wide (75 mm). Reversing (recessing) the rails offsets equipment 2.95" (75 mm) towards the center of the rack so that the side of equipment and airflow through equipment is not blocked by the side of the rack frame. You may also want to reverse (recess) the front mounting rails if you have equipment with a recessed front.

Q. Can I order an additional pair of mounting rails to have two mounting depths in the rack?

A. Yes, you can order an additional pair of fixed mounting rails (P/N 15259-XXX and 15260-XXX). The rack includes a pair of fixed mounting rails that are attached to the front of the frame and a pair of adjustable mounting rails that are attached to the



Frequently Asked Questions

Adjustable Rail QuadraRack™ and ServerRack

rear of the frame. When the additional pair of mounting rails is added, the rails are attached to the rear frame and the adjustable mounting rails (that are included with the rack) are positioned between 15" deep (380 mm) and the rack depth (not the maximum rail depth). Note that the adjustable mounting rails (that are included with the rack) cannot be positioned beyond the depth of the rack. In this configuration, the maximum rail depth is the rack depth 23.62" (600 mm) or 35.43" (900 mm).

Q. Is the rack base pre-punched with floor installation holes?

A. Yes, the rack base is pre-punched with floor installation holes. A pair of holes is located at the front and rear of the rack frame. The holes are 16" (406.4 mm) apart and centered about the width of the rack. Install the rack on concrete slab floors with Rack Installation Kit (P/N 40604-003) and on wood floors with Rack Installation Kit (P/N 40607-001). Use 3/8" or M10 threaded rods to attach the rack to the finished floor in access floor environments.

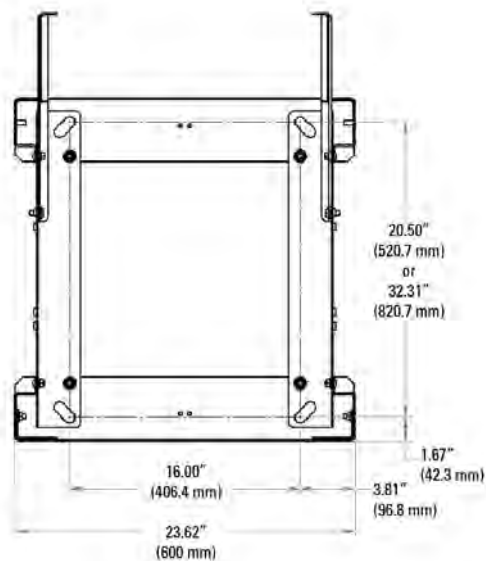

Q. How do I bond the Adjustable Rail QuadraRack or Adjustable Rail ServerRack to the Telecommunications Grounding Busbar (TGB)?

A. The Adjustable Rail QuadraRack and Adjustable Rail ServerRack have a pair of threaded studs pressed into the front and rear base of the frame. The area around the studs is masked. Each rack includes a Two Mounting Hole Ground Terminal Block (P/N 40167-001) and Antioxidant Joint Compound. Remove the masking, apply the joint compound, and install the ground terminal block with included hardware. Then attach an appropriately sized ground conductor (not included) from the ground terminal block to the TGB or signal reference grid.

Q. Are the Adjustable Rail QuadraRack and the Adjustable Rail ServerRack UL Listed?

A. Yes, they are UL Listed 60950.