

Installation Instructions

ADJUSTABLE RAIL SERVERRACK AND QUADRARACK™ EQUIPMENT SUPPORT RAILS

Safety Information



WARNING: Improper use of this product may lead to serious injury or death. Read and understand all instructions for proper installation and use of this product.

Intended Use

Maximum load rating of the support rails is 200 lb.

Tools Required

13mm socket wrench

Included Hardware

10 each
8 mm x
16 mm Bolt

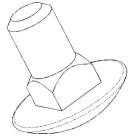

10 each
8mm
Flange Nut



Assembly Sequence

1. Mount the long bracket to the front and rear frames using 2 bolts and nuts; the bolt at the front **must** pass through one of the front angle bracket holes. Note that the support bracket attaches on the outside of the rack and the angles brackets attach on the inside of the rack.
2. The angle brackets are attached to the long bracket with 3 more bolts and nuts.
3. Repeat steps 1 and 2 for the other side of the rack.

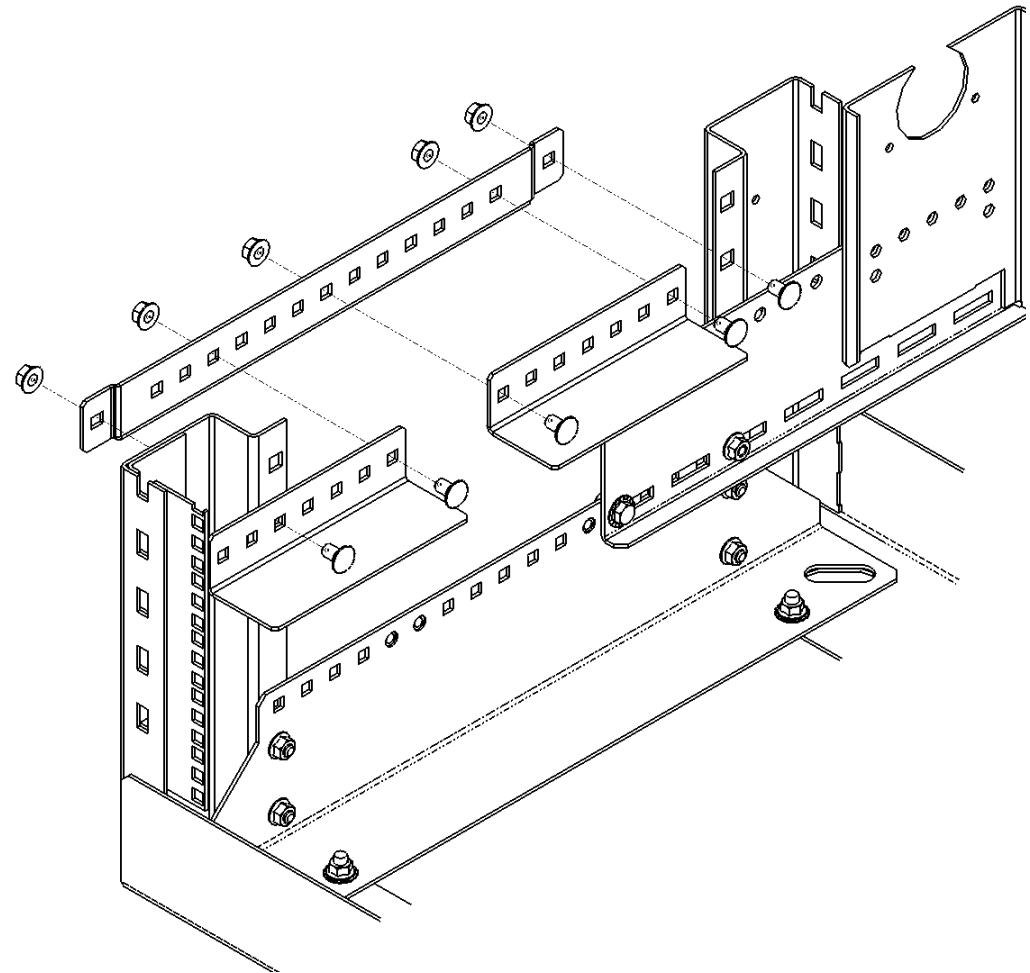

CHATSWORTH PRODUCTS, INC.

IIS-715285, 01/06/10, Rev. 2, CPI/D.Oisboid

800-834-4969 (USA & Canada) • www.chatsworth.com • techsupport@chatsworth.com
For international phone numbers, see our website or contact CPI Tech Support.

This drawing contains proprietary and confidential information and is protected by U.S. and international law. Unauthorized reproduction, disclosure or use of the drawing or the information therein is expressly forbidden except as agreed to in writing by Chatsworth Products, Inc.

Installation Instructions

ADJUSTABLE RAIL SERVERRACK AND QUADRARACK™ EQUIPMENT SUPPORT RAILS

4. If the rack rear rail is mounted in a forward position, there will only be enough room for one angle bracket to be mounted as shown in the picture at the right.

***** For ease of access to mounting locations and bolts, the Equipment Support Rail (15285-X01, 15285-X02) should be installed prior to installing any vertical management pieces on the rack. This sequence is applicable to new rack installations with “planned” positioning of equipment.**

