

Installation Instructions

RMR CORNER BAYING KIT

Safety Information



WARNING: Improper use of this product may lead to serious injury. Read and understand all instructions for proper installation and use of this product.

Included Hardware

(32) M5.5x9 Torx Pan Head Screw

Tools Required

T25 Torx Screw Driver

Assembly Sequence

1. Install rubber seal with adhesive tape along entire cabinet frame side before baying with adjacent cabinet. Starting at the bottom center of the frame side, attach rubber seal by peeling tape liner to expose adhesive. Keep attaching rubber seal along the entire side by slowly peeling tape liner until ending at the starting location.

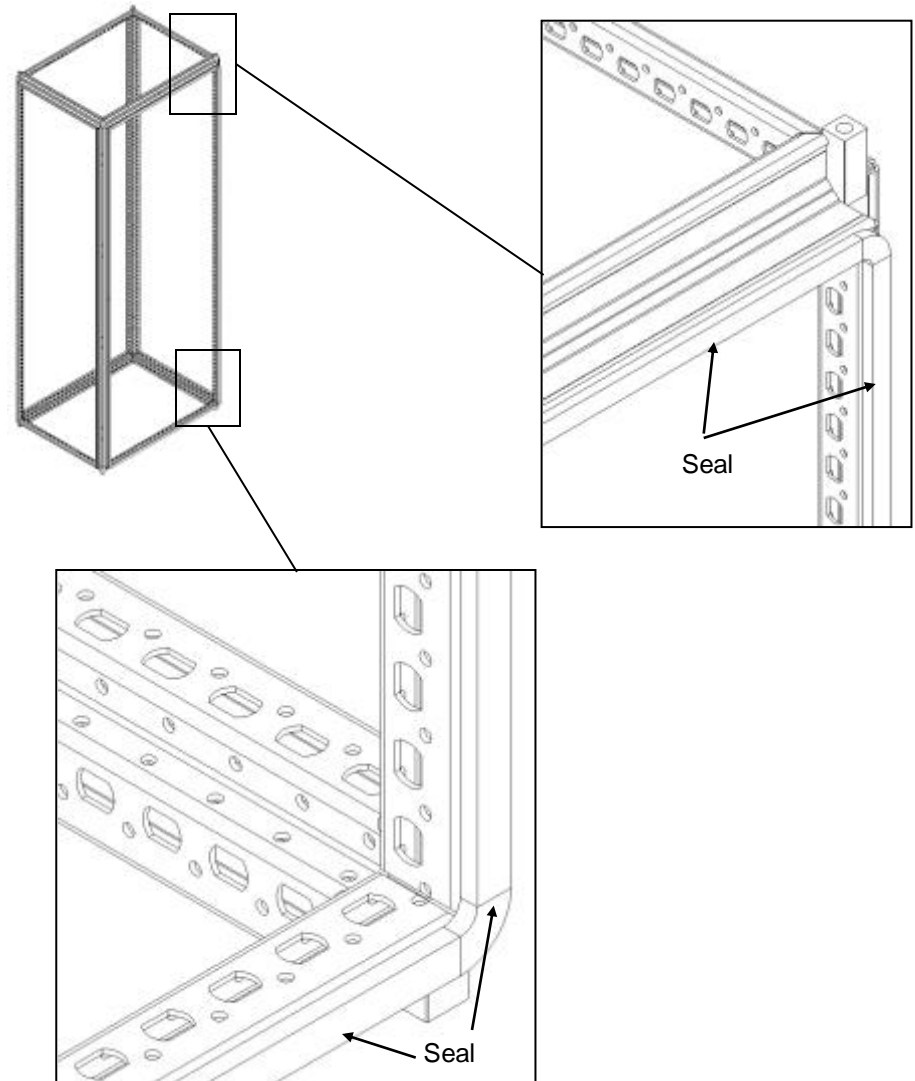

IIS-737825, 08/19/16, Rev. 1, CPI/JAG
800-834-4969 (USA & Canada) • www.chatsworth.com • techsupport@chatsworth.com
For international phone numbers, see our website or contact CPI Tech Support.

This drawing contains proprietary and confidential information and is protected by U.S. and international law. Unauthorized reproduction, disclosure or use of the drawing or the information therein is expressly forbidden except as agreed to in writing by Chatsworth Products, Inc.

Installation Instructions

RMR CORNER BAYING KIT

2. Connect the two cabinets together with an internal corner bracket using M5.5 Torx panhead screws in self-tapping accessory holes.
3. Repeat Step 2 for other three corners where adjacent cabinets connect.
4. Install flat brackets at bottom center along depth members of the internal cabinet frames using four M5.5 Torx panhead screws in self-tapping accessory holes. Repeat flat bracket installation at top center of cabinet frames.
5. Install flat brackets at front vertical frame center of the internal cabinet frames using four M5.5 Torx panhead screws in self-tapping accessory holes. Repeat flat bracket installation at rear vertical frame center of cabinet frames.
6. Corner and flat brackets may also be installed using M6 Drop-in Nut Hardware Kit (37942-001).

