

Installation Instructions

RMR 800MM W FINGER CABLE MANAGER

Safety Information



WARNING: Improper use of this product may lead to serious injury. Read and understand all instructions for proper installation and use of this product.

Tools Required

#2 Phillips Screw Driver

Included Hardware

- (4) M6 Cage nut
- (4) M6X12 Pan head screw

Assembly Sequence

1. Insert M6 cage nuts into accessory holes on equipment rails using a cage nut insertion tool.
2. Attach each finger cable manager bracket onto the equipment rail using M6 screws (Torque 38 IN-LB [4.3 N-M]).

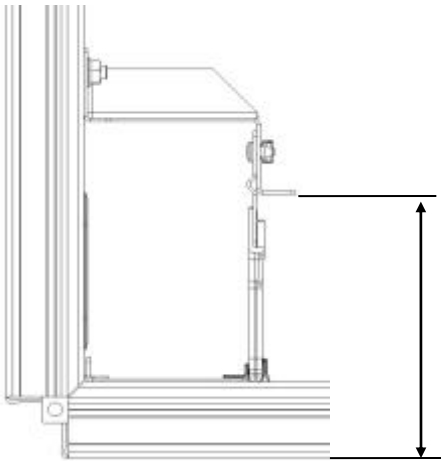

6.31in [160.2mm]
MINIMUM
EQUIPMENT RAIL
SETBACK

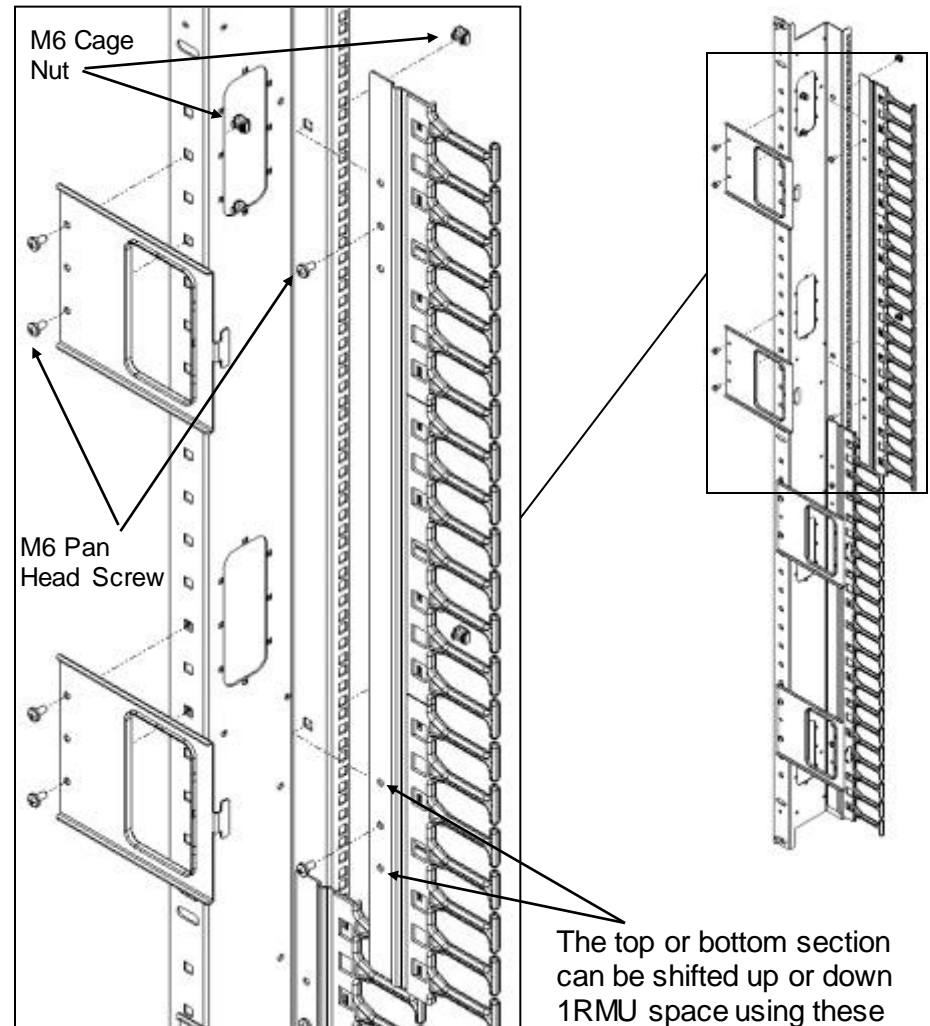

The top or bottom section can be shifted up or down 1RMU space using these holes.



IIS-737860, 07/21/16, Rev. 1, CPI/JAG
800-834-4969 (USA & Canada) • www.chatsworth.com • techsupport@chatsworth.com
For international phone numbers, see our website or contact CPI Tech Support.

This drawing contains proprietary and confidential information and is protected by U.S. and international law. Unauthorized reproduction, disclosure or use of the drawing or the information therein is expressly forbidden except as agreed to in writing by Chatsworth Products, Inc.

Installation Instructions

RMR 800MM W FINGER CABLE MANAGER

3. Attach the door to the fingers by snapping on the hinge cover.
4. Position the door support brackets onto the door slots to align the mounting holes with the equipment rail accessory holes. Attach the door support brackets using two M6 screws (Torque 38 IN-LB [4.3 N-M]).

