



CHATSWORTH  
PRODUCTS

# Cable Runway Radius Bend



## Cable Runway Radius Bend

Creates a gradual bend for cascading cable runs.

- Made of lightweight 1-1/2" x 3/8" (38.1 mm x 9.53 mm) tubular steel
- Three cross members welded at approximately 23° increments
- Outside/Inside is determined by welding cross members closer to cable side
- Gold Bends are UL and cUL Classified

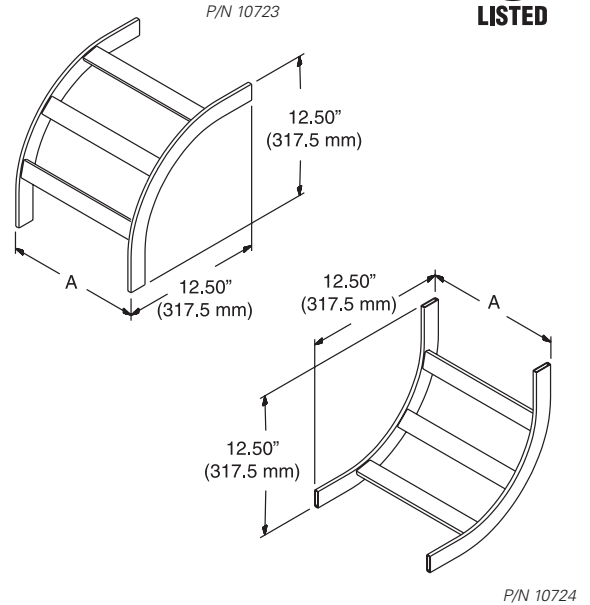

## ORDERING INFORMATION

Part Number 90° Outside Bend	Part Number 90° Inside Bend	Width (Dim. A) in (mm)
10723-X06	10724-X06	6 (150)
10723-X09	10724-X09	9 (230)
10723-X10	10724-X10	10 (250)
10723-X12	10724-X12	12 (300)
10723-X15	10724-X15	15 (380)
10723-X18	10724-X18	18 (460)
10723-X20	10724-X20	20 (510)
10723-X24	10724-X24	24 (610)
10723-X31	10724-X31	30 (760)
10723-X37	10724-X37	36 (910)

X=Color; 0=Gold, 1=Gray, 7=Black, E=Glacier White. Only gold radius bends are UL and cUL Classified

**United States & Canada**  
Simi Valley, CA  
800-834-4969  
Toronto, Ontario, Canada  
+905-850-7770  
chatsworth.com  
techsupport@chatsworth.com

**Latin America**  
Mexico City, Mexico  
+52-55-5203-7525  
Toll Free within Mexico  
800-201-7592  
chatsworth.com.co

**Europe**  
Buckinghamshire  
England, UK  
+44-1628-524-834

**Middle East & Africa**  
Dubai, UAE  
+971-4-2602125

**Asia Pacific**  
Jing'an District,  
Shanghai, China  
+86 21 6880-0266  
chatsworth.com.cn