

Installation Instructions

eConnect® Leak Detector Spot Sensor (Dielectric) – For use with Sensor Hub – Leak Detection

The eConnect® Leak Detector Spot Sensor (Dielectric) – For use with Sensor Hub – Leak Detection is a modular environmental monitoring device engineered for seamless integration with intelligent eConnect® PDUs via the Sensor Hub. It enables real-time detection of dielectric fluid leaks or conductive liquid intrusion within critical infrastructure environments. The sensor provides telemetry data essential for proactive maintenance, risk mitigation, and ensuring operational continuity in datacenter and edge deployments.

The eConnect® Leak Detector Spot Sensor (Dielectric) – For use with Sensor Hub – Leak Detection features magnetic mounting hardware, allowing flexible placement anywhere within the cabinet.

Parts Provided:

- (1) eConnect® Leak Detector Spot Sensor (Dielectric) – For use with Sensor Hub – Leak Detection (13ft cable)
- (2) Push-mount cable ties
- (3) Magnetic cable tie mounts and cable ties (not pictured)
- (4) Cable wrap sleeve
- (5) eConnect® Sensor Hub - Leak Detection (front & rear pictured)
- (6) Ethernet cables (not pictured)

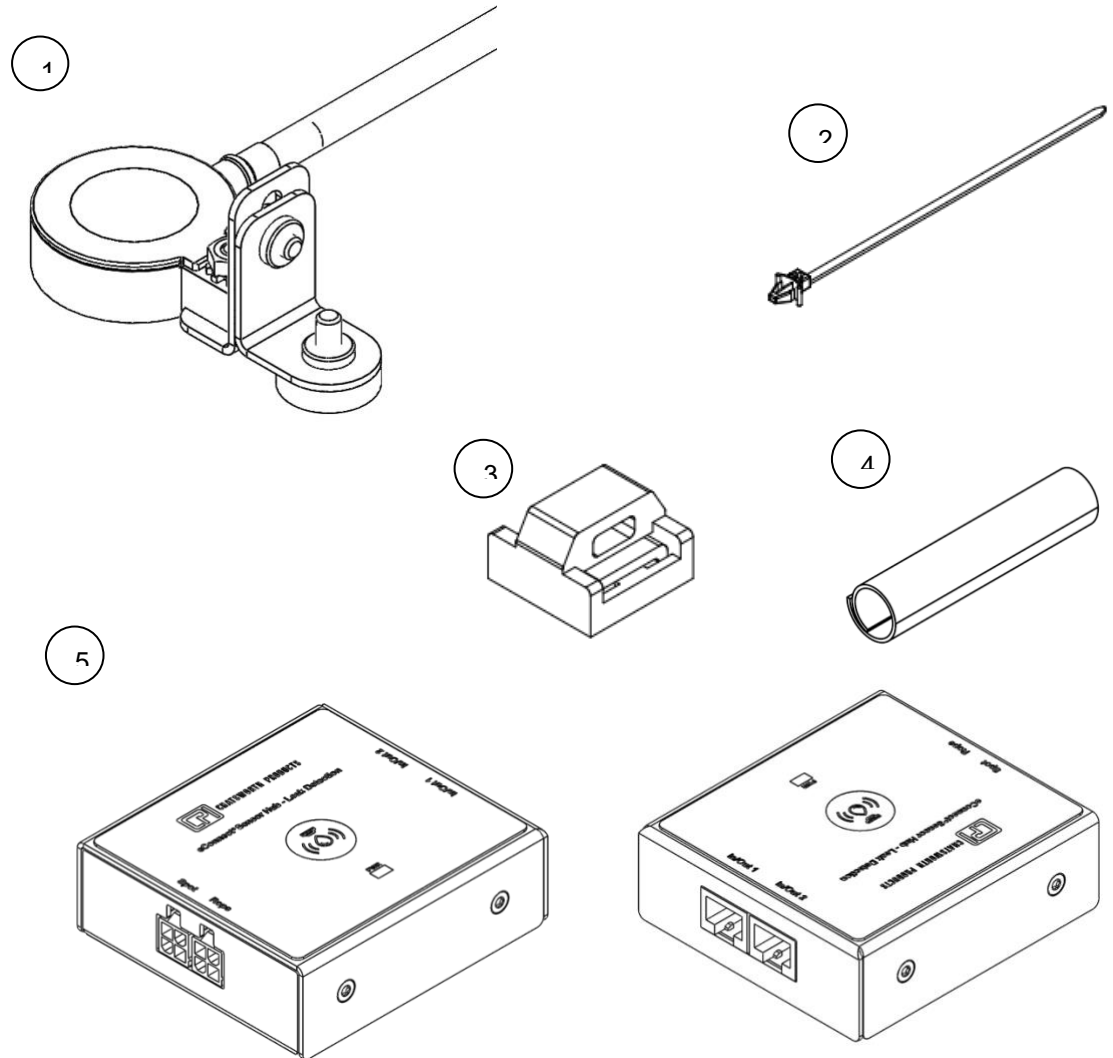

CHATSWORTH PRODUCTS

IIS-714995, 02/18/2026, Rev. 1, S.YOUNIS

800-834-4969 (USA & Canada) • www.chatsworth.com • techsupport@chatsworth.com

For international phone numbers, see our website or contact CPI Tech Support.

This drawing contains proprietary and confidential information and is protected by U.S. and international law. Unauthorized reproduction, disclosure or use of the drawing or the information therein is expressly forbidden except as agreed to in writing by Chatsworth Products, Inc.

Installation Instructions

eConnect® Leak Detector Spot Sensor (Dielectric) - Installation

Dielectric Leak Detector Spot Sensor:

- Locate the area where leaks are most likely to first appear and where the liquid will accumulate. This placement will ensure early detection and effective monitoring of potential leaks.
- Place sensor on drip tray/pan. With the T10 Torx screwdriver, set height of sensor based on required sensitivity by adjusting brackets.
- If required, adjust angle to accommodate the drip tray.
- Plug the sensor into the “Spot” port of the *eConnect® Sensor Hub - Leak Detection*.

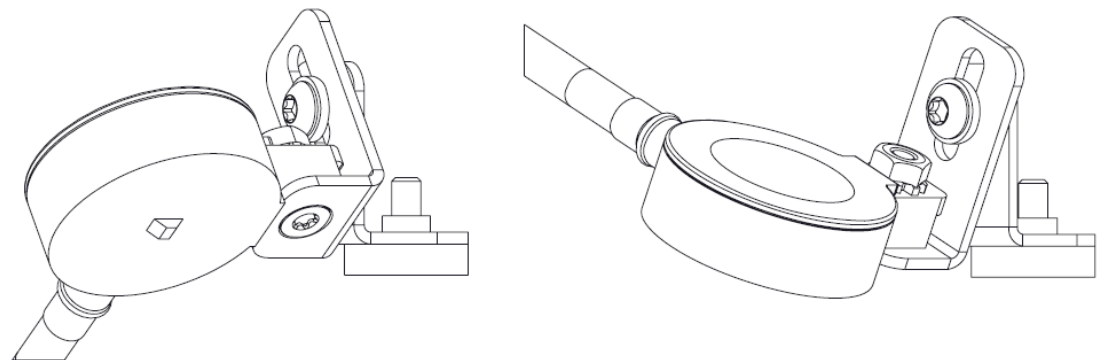
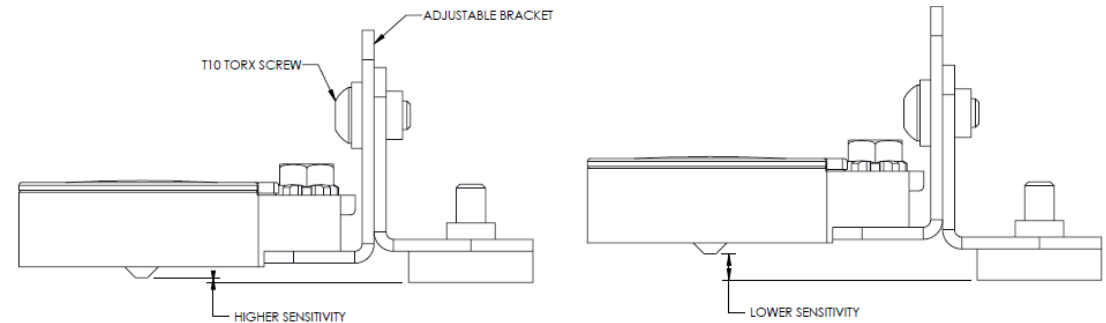

Installation Instructions

eConnect[®] WebUI Setup

EXTENDED SENSOR PLATFORM SETUP INSTRUCTIONS:

The following section will provide step-by-step instructions for the initial software configuration and setup required for the CPI extended sensor platform. Configuring the PDU's will require WebUI access. This can be accomplished either with direct Ethernet access to each PDU, or with Ethernet access to the Primary PDU of an eConnect SecureArray™ configuration. To complete the necessary software configuration, execute the following steps:

1. Plug in the end of Sensor Array into Aux 2 port of PDU.
 - a. If using a secondary PDU with array, plug other end of array into Aux 2 port of 2nd PDU.
2. Access the PDU's WebUI.
3. Navigate to the PDU's "Settings" tab.
 - a. The "PDU Settings" page will be shown.
4. Next to "Aux Port Usage:", select the "Extended Sensor Platform" radio button. A few configurable items will now be enabled, where they were previously disabled:
 - a. The "Controller Negotiation:" options will be enabled with the "Auto-Negotiation" option selected.
 - b. The "Lead Override" checkbox will be enabled, but not selected.
5. Click "Save".
6. All modules will now initialize and begin reading and reporting data.

FW UPGRADE FUNCTIONALITY:

1. The Extended Sensor Platform has the capability to receive FW upgrades from the PDU WebUI.
2. To initiate a FW upgrade, first click on the "Administration" tab.
3. Next select the "Upgrade Firmware" page.
4. There will be a section at the bottom where a .bin file can be uploaded to upgrade the FW for all modules connected to that PDU.
 - a. This section will also display the current FW version that each module currently is running.
5. After FW upgrade is initiated, a progress bar will be present to display how far along the upgrade is.
6. After FW upgrade is completed, this section will update and display the new FW version for each module flashed.