

# Installation Instructions

## ADJUSTABLE SERVERRACK AND QUADRARACK CABLE RUNWAY MOUNTING BRACKET

### Safety Information



**WARNING:** Improper use of this product may lead to serious injury or death. Read and understand all instructions for proper installation and use of this product.

### Tools Required

Two 1/2" open end wrenches

### Included Hardware

2 each  
J Bolt

2 each  
5/16-18 x 3/4  
Hex Bolt

4 each  
5/16-18  
Hex Nut

4 each  
5/16  
Lock Washer

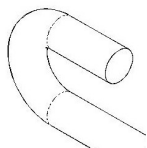

### Assembly Sequence for Parallel Runway Mounting

For Rack Depths of 400 mm up to 675 mm

1. The bracket can be mounted to any of the holes on the rack frame top angles indicated in the picture at the right.
2. Mount the bracket with two each of the 5/16-18 x 3/4 bolt, 5/16 lock washer and 5/16-18 nuts. The picture below shows a 625 mm deep rack so the bolts use the holes at the very end of the bracket. The other holes are for shallower depth racks.

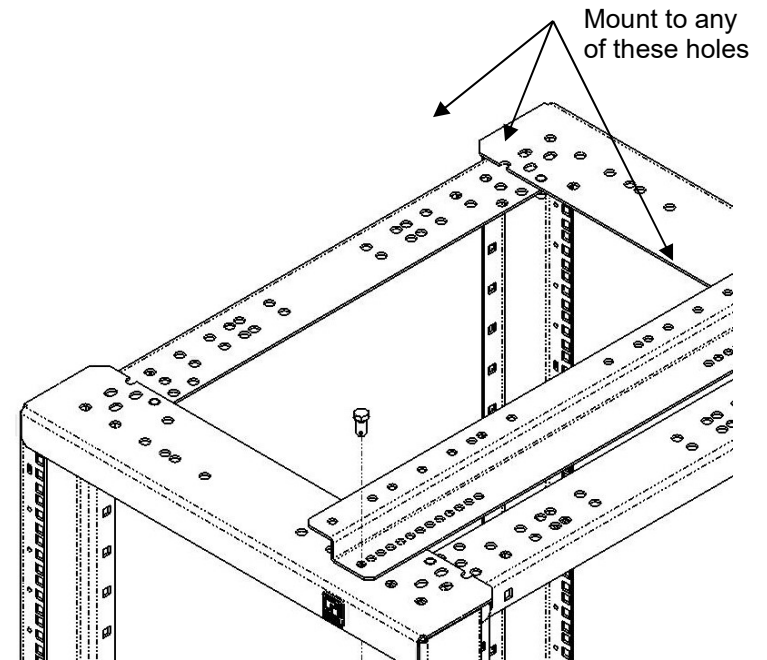

CHATSWORTH PRODUC

IIS-715205, 01/06/10, Rev. 2, CPI/B Krietzman

800-834-4969 (USA & Canada) • [www.chatsworth.com](http://www.chatsworth.com) • [techsupport@chatsworth.com](mailto:techsupport@chatsworth.com)

For international phone numbers, see our website or contact CPI Tech Support.

*This drawing contains proprietary and confidential information and is protected by U.S. and international law. Unauthorized reproduction, disclosure or use of the drawing or the information therein is expressly forbidden except as agreed to in writing by Chatsworth Products, Inc.*

# Installation Instructions

## ADJUSTABLE SERVERRACK AND QUADRARACK CABLE RUNWAY MOUNTING BRACKET

### Assembly Sequence for Parallel Runway Mounting

#### For All Rack Depths

1. The bracket can be mounted to the holes on the rack top brackets indicated in the picture below. Use the holes closest to the rack frame.
2. Mount the bracket with two each of the 5/16-18 x 3/4 bolt, 5/16 lock washer and 5/16-18 nuts.

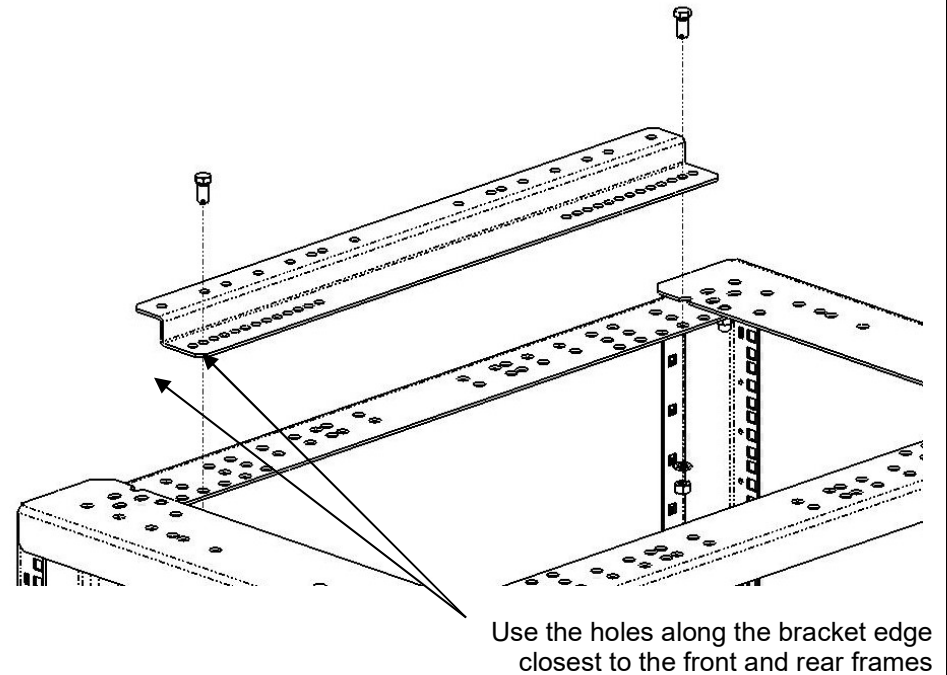

# Installation Instructions

## ADJUSTABLE SERVERRACK AND QUADRARACK CABLE RUNWAY MOUNTING BRACKET

### Assembly Sequence for Perpendicular Runway Mounting

1. Mount the bracket with two each of the 5/16-18 x 3/4 bolt, 5/16 lock washer and 5/16-18 nuts as shown below.

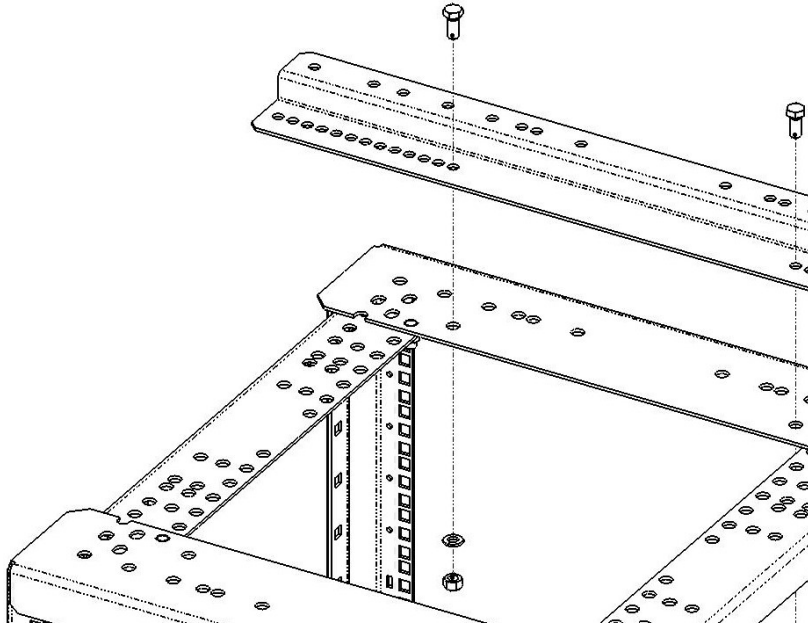

### Mounting the Runway

1. Mount the runway with two each of the J-bolt, 5/16 lock washer and 5/16-18 nuts as shown below. The runway will be centered on the bracket; a 15" wide runway is shown.

